

Fault Detection in Cluster Microgrids of Urban Community using Multi-Resolution Technique Based Wavelet Transforms

S. N. V. Bramareswara Rao*[‡], N. Rama Narayana*, T. Deepti Prasanna*, M. S. N. L. Narasimha Rao*, P. Gowri Chand**

*Assistant Professor, Department of EEE, Sir C. R. R. College of Engineering, Eluru, West Godavari Dist., A.P-534007, India

**M. Tech. Student, Department of EEE, Sir C. R. R. College of Engineering, Eluru, West Godavari Dist., A.P-534007, India

(snvbrao.eee@sircrrengg.ac.in, ramanarayana1@sircrrengg.ac.in, tata.deepti@sircrrengg.ac.in, lakshminarasimha19@gmail.com, gchand056@gmail.com)

[‡]Corresponding Author; S. N. V. Bramareswara Rao, Assistant Professor, Department of EEE, Sir C. R. R. College of Engineering, Eluru, West Godavari Dist., A.P-534007, India

Tel: +91 08812 230840, snvbrao.eee@sircrrengg.ac.in

Received: 28.05.2022 Accepted:13.06.2022

Abstract- Due to significant distributed generator penetrations, microgrid protection issues have an impact on power system reliability. As a result, fault identification and protection in microgrids are critical and must be addressed to improve the power system's robustness. If any fault arises in or outside the microgrid (MG), the microgrid should get disconnected from the main grid promptly using a static switch like a circuit breaker situated near the point of common coupling (PCC). To supply reliable and quality power to the consumer by reducing the burden on the utility grid this paper proposes a "Cluster Microgrid System". The proposed system is formed by integrating neighbourhood microgrids and is designed to operate both in autonomous and grid-connected modes. Moreover, Wavelet Transformation based frequency multi-resolution technique is also proposed for detecting different type's faults appearing in different locations of a cluster microgrid system. To locate these faults, the Daubechies-4 wavelet decomposes the extracted signal into detailed and approximated signals along with the two-terminal traveling wave phenomenon. The proposed wavelet transform-based cluster microgrid system is implemented in MATLAB/Simulink 2021a environment. To verify the robustness of the proposed system, the proposed Wavelet Transform (WT), and Wavelet Packet Transform (WPT) techniques are analyzed and compared by considering performance indices such as standard deviation and mean absolute deviation, median absolute deviation, and entropy. From the results, it is observed that WPT gives fruitful results when compared with WT.

Keywords Microgrid, Wavelet Transform (WT), Wavelet Packet Transform (WPT), Cluster Microgrid, Utility grid.

Nomenclature

CMG	Cluster Microgrid	MG	Microgrid
DG	Distributed Generation	PCC	Point of Common Coupling
DWT	Discrete Wavelet Transform	WT	Wavelet Transform
EMS	Energy Management System	WPT	Wavelet Packet Transform
HPF	High Pass Filter		
LPF	Low Pass Filter		

1. Introduction

Advances in distributed generators (DGs) have been crucial in addressing the challenges with conventional power system networks for the past several years. The substantial growth of DGs provides a potential answer to the non-availability and fatigue of fossil fuels, as well as fast growth in electric loads, environmental pollution, and the high cost of petroleum products and gases. DGs have been quite successful in addressing a variety of technological, governing, and current problems in the traditional electric system [1]. Microgrids, which are low voltage active distribution networks, have replaced the traditional electric power system as a result of this innovative technology. A microgrid (MG) is a combination of distributed generation (DGs), energy storage elements, and a variety of loads that can be controlled via monitoring and protection systems [2]. Microgrids are frequently connected to the main grid at the distribution side with the use of a circuit breaker at the point of common coupling (PCC). Under typical operating conditions, the microgrid is synchronized with the utility. In case the conventional grid faces any issues like fluctuations in voltage or frequency, it will be disconnected from the utility grid and operates in an islanded mode to meet critical demands [3]. Due to the less energy density of MG and reliance on regional topographical factors, they are vulnerable to climate change; DGs in a microgrid have significantly less capacity than huge generators in traditional systems. They are close to consumers to provide the right voltage and frequency to electric and heat loads with minimal transmission losses to avoid congestion of the power network. They improve the current power system's technical standards, economic aspects, and reliability of the environment by maintaining electricity while the regular power supply is available. Large fluctuations in some system parameters may occur as a result of such disruptions, potentially leading to power system instability. As a result, to preserve power supply continuity, these disruptions must be noticed and addressed quickly. According to IEEE 1547, the concept of interconnected microgrids is the prominent solution for delivering reliable and stable power to the consumer without creating much burden on the utility grid [4, 5]. The ability of the electric power system to maintain a desirable level of performance in the face of severe turbulence and restore it over a reasonable length of time is characterised as resilience [6]. Hence, it is very important to identify the type of fault/disturbance occurs inside or outside the microgrid for operating the system effectively without load shedding. This paper mainly focussed on identifying the type of fault in different locations in the system proposed [7]. In this aspect following are some literature works carried out for identification of the fault in microgrids.

In reference [8] a complete review of diagnosis methods of various faults in the power transmission system is provided. The samples of voltage and currents are commonly used for analysis. Three major and important tasks are provided independently to communicate a more logical and thorough grasp of the concepts including detection, categorization, and location of the fault. Extraction of features and modifications using dimensionality reduction approaches are explored. In [9] author presents a fault detector for the protection of three-phase transmission lines

with series capacitor compensation using wavelet transform. In [10], the authors provided a novel technique for detecting and classifying various microgrid problems. Using a multi-resolution method, a Wavelet Neural Network (WNN) is used to identify and extract features to characterize various faulty signals. In [11], a criterion method based on the chaotic neural network (CNN) and a defect detection approach based on the discrete wavelet transform (DWT) is proposed for effective fault detection. A microgrid fault protection system based on a combination of signal processing and data mining is presented in [12]. The voltage and current signals are pre-processed using the multi-resolution decomposition of the wavelet transform to compute the total harmonic distortion of the voltage and current signals. However, in real time, new algorithm-based fault detection is utilized to apply the dq0 and wavelet transformation to local measurements [13]. This method involves converting three-phase voltage or current signals into dq0 components and analysing their behaviour during faults to identify patterns that indicate the commencement of a problem. However, in [14] authors proposed a new failure detection approach based on wavelet transform (WT) for motor and which uses an improved particle swarm optimization (PSO) and a back propagation (BP) neural network. Authors in [15] suggested a wavelet transform (WT)-based fault detection approach for hydrogen energy-based distributed generator systems to detect power quality disturbances in the low-voltage grid link. Using discrete WT and Daubechies wavelets of order 4, the proposed approach detects voltage swell, voltage sag, voltage interruption, and transient disturbances in a proposed system. Later in [16] a comprehensive review of fault detection methods like conventional and artificial intelligence methods is presented. Reference [17] suggested a method that combines the linear discriminant analysis (LDA) with the cuttlefish optimizer (CFO) learning process-based random forest algorithm (RFA) for fault diagnosis in the power system. In [18] the study of a critical analysis of various faults detection strategies and classifying the faults using model-based and data-driven methods are presented. The characteristics of a microgrid under various operating scenarios of a faulty component, such as impedance (high as well as low) failures, are described in [19] using fault models from a grid-connected PQ controlled DG with a low voltage ride through capacity (LVRT). Reference [20] provides an overview of MG fault diagnosis strategies, as well as their constraints, and a new discrete-wavelet transform (DWT) based probabilistic method for MG fault diagnosis is proposed. The suggested model consists of numerous layers and a restricted Boltzmann machine (RBM), which permits the model to reconstruct probability over its inputs. Later in [21], a study is presented under varied DG voltages and fault conditions, detection of a fault in microgrids by controlling power quality, and DGs with low voltage ride through capability which includes high impedance and low impedance. The positive sequence current phase variation in the particular DG voltages was used to pinpoint the location of the defect. The research in [22] offers a new fault identification approach for low voltage DC microgrids with RES to establish a practical method. The suggested new fault detection approach uses the instantaneous current change

rate, the DWT detail coefficient, and absolute detailed energy.

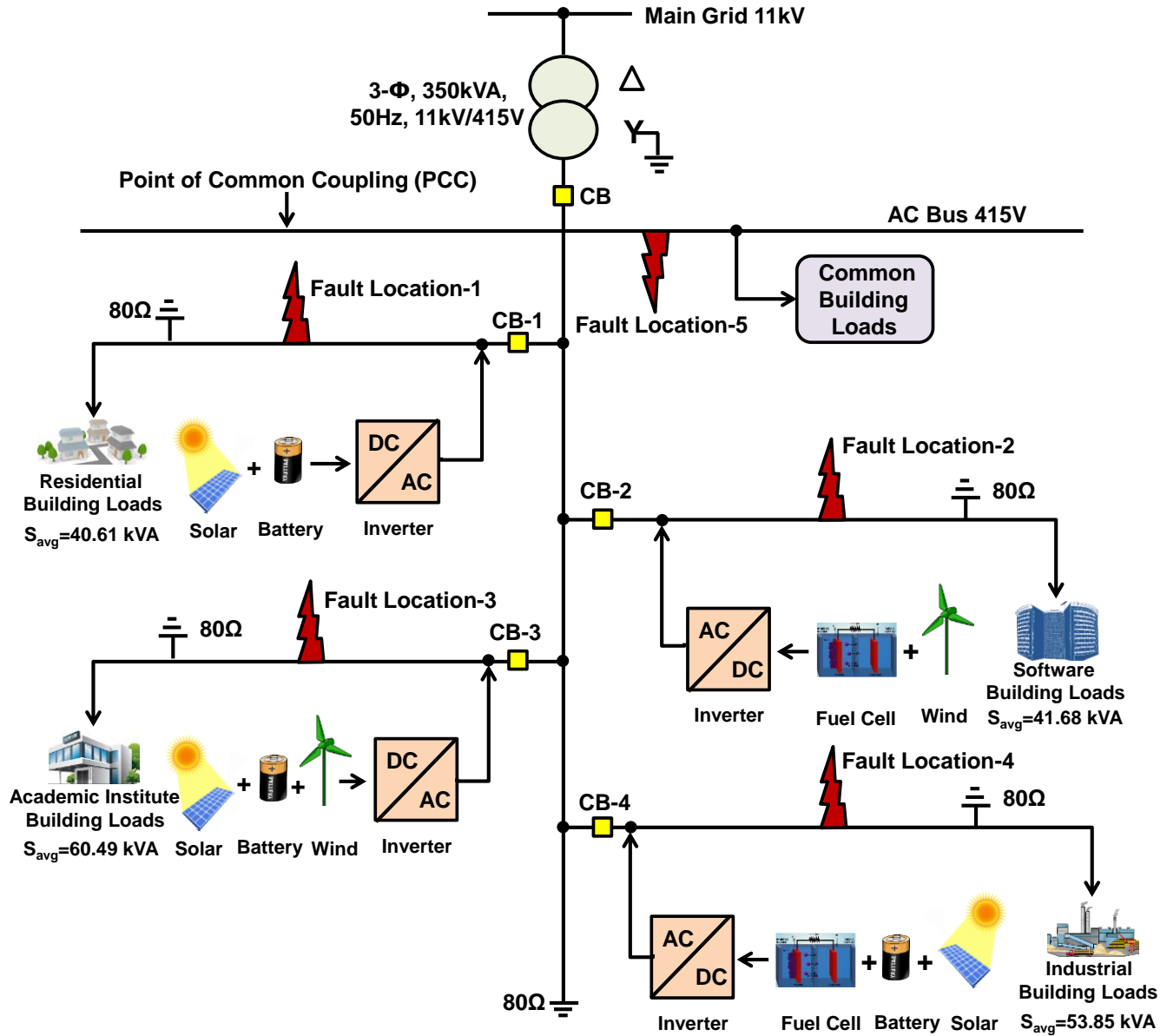

Fig. 1. One line diagram of proposed cluster microgrid system

Based on fault launched traveling waves, reference [23] proposes a new technique for detecting, classifying, and locating various dc fault types in MVDC microgrids (TWs).

So far the many researchers have developed and proposed conventional approaches (Travelling wave-based) and artificial intelligence techniques for the detection of faults in a single microgrid operated in grid-connected and isolated modes. By keeping this in mind, in this paper we proposed a cluster microgrid system by integrating adjacent microgrids with interoperability and also proposed frequency multi resolution-based wavelet packet transform approach for the detection of faults in the proposed system.

So, the following are the key contributions of this paper:

- Formation of a renewable-energy-based microgrid cluster by interconnecting numerous adjacent microgrids in

an urban energy community is proposed. This improves power supply reliability by allowing the cluster to handle its own energy needs rather than relying on the utility grid.

- Multi-Resolution based Wavelet Transformation and Wavelet Packet Transformation approaches are proposed by extracting frequency information for fault detection.

The rest of the article is structured as follows. Section 2 consists of the architecture of the proposed cluster microgrid system, Section 3 presents a concept of Multi-Resolution based Wavelet Transforms, Section 4 discusses the validation of results followed by the conclusion presented in Section 5.

2. Architecture of Cluster Microgrid System

Figure 1 shows the one-line diagram of the proposed “Cluster Microgrid (CMG)” system under study. The proposed CMG system is designed by integrating four microgrids (MG₁-MG₄) and each MG is associated with localized renewable sources. The detailed modeling of all the constituent units in the system is given in [24]. The voltage received from renewable energy sources is very less and not adequate to light the required load demand in the MG since the power provided from these sources is periodic. By increasing the duty ratio of the converter, the voltage is raised to 500V to supply the AC loads with 415V. To meet the loads, each microgrid is modeled using a combination of free and paid energy sources, a boost converter, and a multilevel inverter. The ratings of all the components are given in Appendix-A. In the system total of five fault locations viz., Location 1 at MG₁, Location 2 at MG₂, Location 3 at MG₃, Location 4 at MG₄, and Location 5 is a point of common coupling (PCC) are selected to detect and classify the type of fault. The key goal of the proposed cluster microgrid is to supply uninterrupted and quality power [28] to the consumer premises without much dependency on the utility grid. So, the focus now shifted to Location 5 appeared at the PCC of the system. The Energy management system (EMS) is developed according to accomplish the energy transaction in the proposed system during excess/deficit power conditions [1, 27]. Whenever a fault exists in a particular microgrid that will be disconnected from the cluster microgrid system and the remaining microgrids will share the load to provide continuous and reliable power to the consumer. Accordingly, the EMS will send the trip signals to the circuit breakers at the load side of each microgrid to avoid unwanted shortages from the abnormal conditions. The details of the different renewable energy sources used in the microgrids in a cluster are given in Table 1.

Table 1. Details of resources used in the proposed system

Microgrid	Resource	Power (kW)	Power (kVA)
1	Solar PV and Battery	4.25	40.61
2	Wind & Fuel cell	2.75	41.68
3	Solar, Wind & Battery	4.5	60.49
4	Solar, Fuel cell & Battery	4	53.85

3. Proposed Methodology

3.1. Theory of Wavelet Transform (WT)Figure Properties

Wavelet Transform is a signal processing technique that uses a “Time-Frequency multi-resolution” approach to analyze power system disruptions. It makes use of a movable window that shrinks at high frequencies and expands at lower frequencies. Mother wavelets consist a set of basis

functions which are then used to split the signal function into distinct frequency levels using continuous expansion and interpretation operations. Wavelet transforms can depict functions and manifest their local properties in the time-frequency domain at the same time. These qualities make it easier to train neural networks accurately to model exceedingly nonlinear signals. A given function (signal) can be expressed as a sum of wavelets and scalable functions with coefficients at various time shifts and scales using the Discrete Wavelet Transform (DWT) (frequency). By deconstructing signal components that overlap in both time and frequency, DWT may extract information from transitory signals [25, 26]. As per the Discrete Wavelet Transform (DWT), the approximation and detailed coefficients of a time series signal $\alpha(\tau)$ can be decomposed by using the scaled function $\delta_j(\tau)$ and mother wavelet function $\mu_j(\tau)$ as given in Eq. (1) and Eq. (2).

$$\delta_{jn}(\tau) = 2^{-j} \delta(\tau - k) \tag{1}$$

$$\mu_{jn}(\tau) = 2^{-j} \mu(\tau - k) \tag{2}$$

Where $k \in \mathbb{Z}, n, j$ are integers, the basic function is translated by ‘k’ units of time and ascended by a factor of 2^j . The scalable function is coupled to a low-pass filter (LPF) with coefficients (k) of the filter. With this filter coefficient, function of the wavelet is coupled to a high-pass filter (HPF) (k) are given in Eq. (3) and Eq. (4) [12, 26].

$$\delta(\tau) = \sum_k h(k) \sqrt{2} \delta(2\tau - k) \tag{3}$$

$$\mu(\tau) = \sum_k g(k) \sqrt{2} \delta(2\tau - k) \tag{4}$$

Figure 2 shows the procedure of detailed coefficients decomposition using the wavelet by taking a sample level N=3.

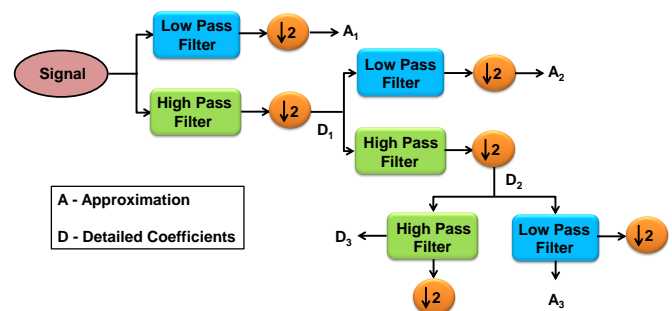

Fig. 2. Detailed coefficients decomposition procedure using wavelet for level 3

3.2. Theory of Wavelet Packet Transform (WPT)

In the general step, the orthogonal wavelet decomposition approach divides the approximated coefficients into two halves. We now have approximated coefficient vector and detailed coefficient vector on a coarser

scale as a result of splitting. The detail coefficients indicate the information lost between two subsequent approximations. After that, the new approximation coefficient vector is divided, and no further features are re-examined. Each detail vector coefficient is similarly split into two pieces in the matching wavelet packet scenario, using the same approach as in approximation vector splitting. This is the most comprehensive analysis: As shown in Fig. 3, a complete binary tree can be produced [24]. Decomposition with Multi-Resolution Technique is a highly accessible discrete wavelet transform (DWT) approach. Mallat was the first to offer multi-resolution signal decomposition theory as a mathematical model. At any level N, the multi-resolution decomposition of a time-varying signal is written as given in Eq. (5).

$$f(\tau) = \sum_k a_{N,k} \frac{\mu}{\sqrt{2^N}} \left(\frac{\tau}{2^N} - k \right) + \sum_k \sum_k d_{ik} \frac{\mu}{\sqrt{2^i}} \left(\frac{\tau}{2^i} - k \right) \quad (5)$$

$$\cong A_n(\tau) + \sum_i D_i(\tau)$$

here $a_{N,k}$ is approximated low frequency and $d_{i,k}$ is detailed coefficient of high frequency components of original signal at the level 'N'. A filter bank can be assumed as the DWT. The approximation and detailed coefficients are obtained by passing the sampled signal $f(\tau)$ through a LPF, $H = h(k)$ and a HPF, $G = g(k)$.

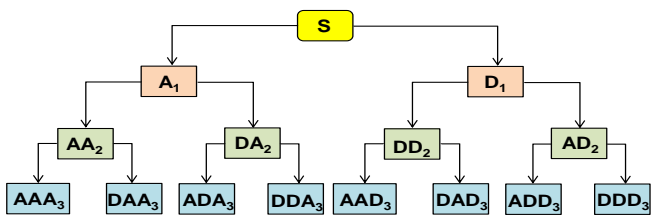

Fig. 3. Detailed coefficients decomposition procedure by wavelet packet for level 3

Following is the step-by-step approach for multi resolution technique for a 3 level decomposition.

1. The input signal is decomposed into detailed (D_1) and approximation (A_1) coefficients with a frequency bands of $\left(\frac{f_s}{2} - \frac{f_s}{4}\right) kHz$ for D_1 and $\left(\frac{f_s}{4} - 0\right) kHz$ for A_1 .
2. The output sample is down by a factor of 2 for both low pass and high pass filters.
3. For further decomposition D_1 is directed to next stage to yield new set coefficients.
4. In later stage D_2 is collected in the range $\left(\frac{f_s}{4} - \frac{f_s}{8}\right) kHz$ and A_2 is collected in the range $\left(\frac{f_s}{8} - 0\right) kHz$.

The above procedure is repeated for the 'n' number of decompositions. The code for detecting faults in different

locations using MATLAB is shown in Fig.4. The flow chart of fault detection using wavelet transformations is shown in Fig. 5.

```

clc
clear all
1. Initialize the currents and voltages at PCC of cluster microgrid;
2. [C, L]= wavedec (x, N, wavelet name); -----> Wavelet Syntax applied on signal
   where wavedec - Function used to decompose the signal
       x - Signal
       N - Layer of wavelet (default=1)
       wavelet name - Type of wavelet used (Daubechies)
       C - output layer decomposition vector
       L - No. of coefficients by layer
3. D = detcoef (C, L, N); -----> Wavelet Syntax for detailed coefficients
   where detcoef - Function used to obtain detailed coefficients of the signal
       D - Extract the detailed coefficients at the coarsest scale
4. Define new variables m, n, p, q as maximum values of coefficients extracted
5. if m > Threshold
   if n > Threshold
   if p > Threshold
   if q > Threshold
       display (' Three phase to ground fault is detected ')
   end
   end
   end
   end
6. Repeat the step 5 for different faults such as LG,LL,LLG,LLL and no fault condition
    
```

Fig. 4. MATLAB code for fault detection

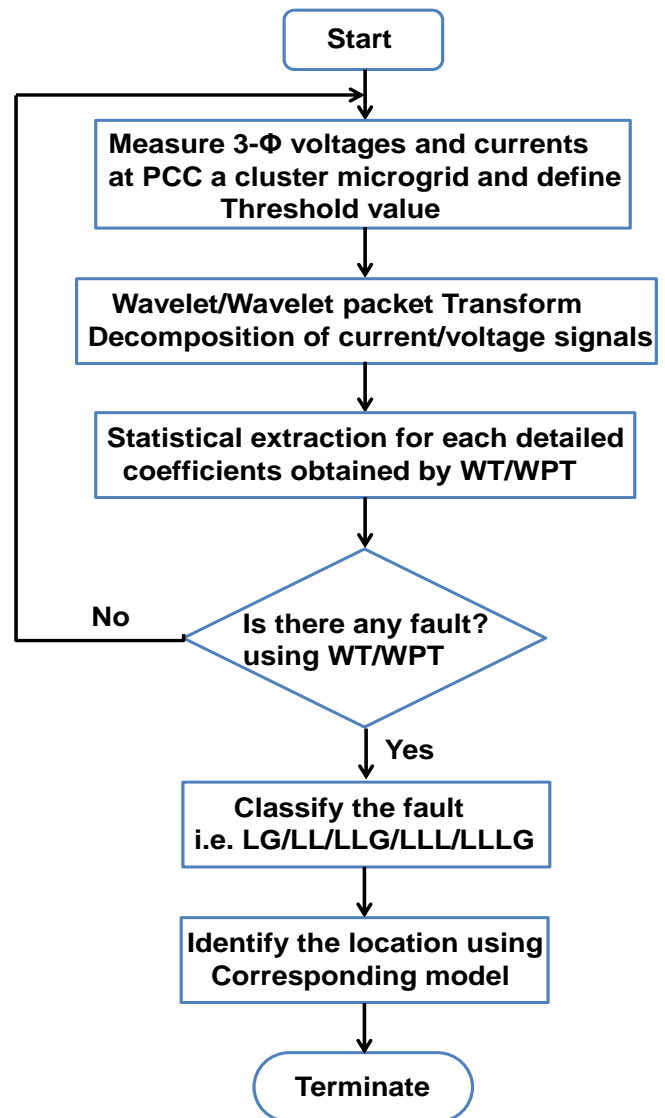

Fig. 5. Flow chart of proposed WT/WPT implemented in MATLAB/Simulink

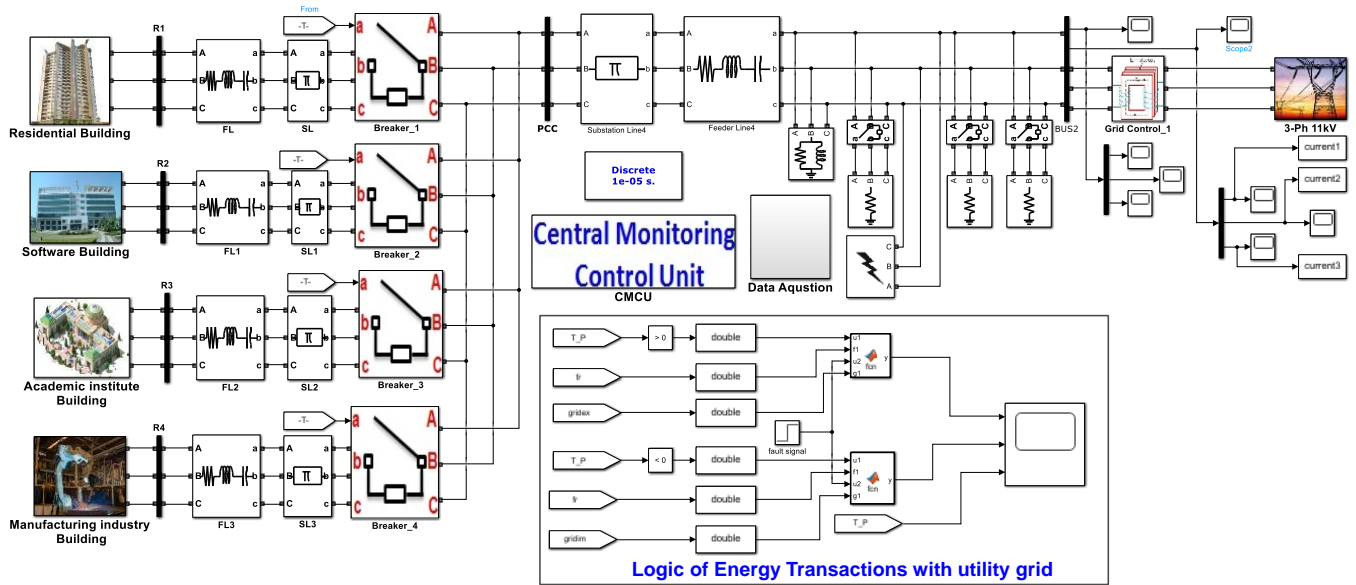

Fig. 6. MATLAB/Simulink implementation of proposed cluster microgrid system

4. Analysis of Simulation Findings and Discussion

In this section, the simulated graphical results are obtained and analyzed by the proposed methodologies WTs and WPTs, after the results are compared quantitatively based on performance parameters such as standard deviation, median absolute, mean absolute, and entropy, which are used to identify discrete fault disturbances. As illustrated in Fig. 6, the cluster microgrid is attached to the main utility grid and is modeled in the MATLAB/ Simulink environment in various operational scenarios employing solar, wind, fuel cells, and storage batteries.

4.1. Case 1: Fault detection in a cluster microgrid system

In this subsection, various fault disturbances are formed at the cluster microgrid, which includes LG (Line to ground), LL (Line to Line), LL-G (Line to Line to ground), LLL (three phase), LLL-G (Three phase to ground). The faults under investigation include a combination of symmetrical and unsymmetrical faults, providing a diversity of disturbances to test the resilience of the suggested approaches. A fault simulator in MATLAB/Simulink's power system is used to create faults in the microgrid cluster. At first, the line-to-ground fault is applied at the PCC of cluster MG with a duration of 0.1 sec to 0.2 sec. The voltage magnitude drops at 0.1 sec immediately after the occurrence of fault and regains its original magnitude at 0.2 sec at which the fault is cleared. The simulated results obtained by passing this voltage signal through “WT” and “WPT” are displayed in the Fig. 7(a). It is identified that both methods are capable of detecting faults in a timely and accurate manner. The detailed coefficient is shown in Fig. 7(b) by considering level one. From the contour plots, the color coding in both transforms changes throughout the fault,

which aids in detecting the voltage signal disturbance. The efficacy of proposed methodologies are being tested by adding a 40-dB noise signal to the voltage function, detection results are displayed in figures 7(c) and 7(d). WT and WPT are used to pass this voltage signal with noise. Wavelet Transform is unsuccessful to identify the variations in the magnitude of voltage during the fault time, resulting in no discernible color changes in the contour. The contour displays the fluctuations during the LG fault in the case of the wavelet packet, indicating its effectiveness in detecting voltage signal irregularities in noisy situations.

Similarly, next, the line-to-line fault is created at the PCC of cluster MG with a duration of 0.1 sec to 0.2 sec. The voltage magnitude drops at 0.1 sec immediately after the occurrence of fault and regains its original magnitude at 0.2 sec at which the fault is cleared. The simulated results obtained by passing this voltage signal through “WT” and “WPT” are displayed in the Fig. 8(a). Similar to the previous case again it is identified that both methods are capable of detecting faults in a timely and accurate manner. The detailed coefficient by considering level one is shown in Fig. 8(b). From the contour plots, the color coding in both transforms changes throughout the fault, which aids in detecting the voltage signal disturbance. The efficacy of proposed methodologies are being tested by adding a 40-dB noise signal to the voltage function, detection results are displayed in figures 8(c) and 8(d). WT and WPT are used to pass this voltage signal with noise. Wavelet Transform is unsuccessful to identify the variations in the magnitude of voltage during the fault time, resulting in no discernible color changes in the contour. The contour displays the fluctuations during the LL fault in the case of the wavelet packet, indicating its effectiveness in detecting voltage signal irregularities in noisy situations.

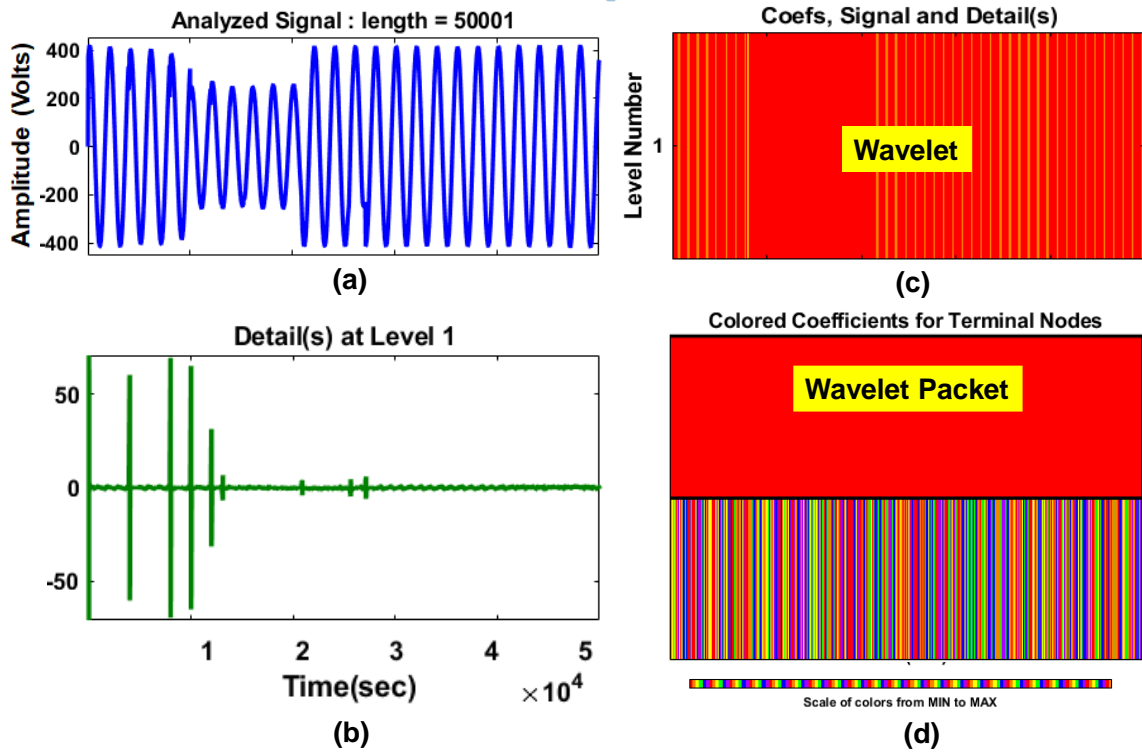

Fig. 7. LG fault (phase A) detection at PCC of cluster microgrid a) voltage signal b) detail coefficient c) contour plot of wavelet transform (WT) d) contour plot of wavelet packet transform (WPT)

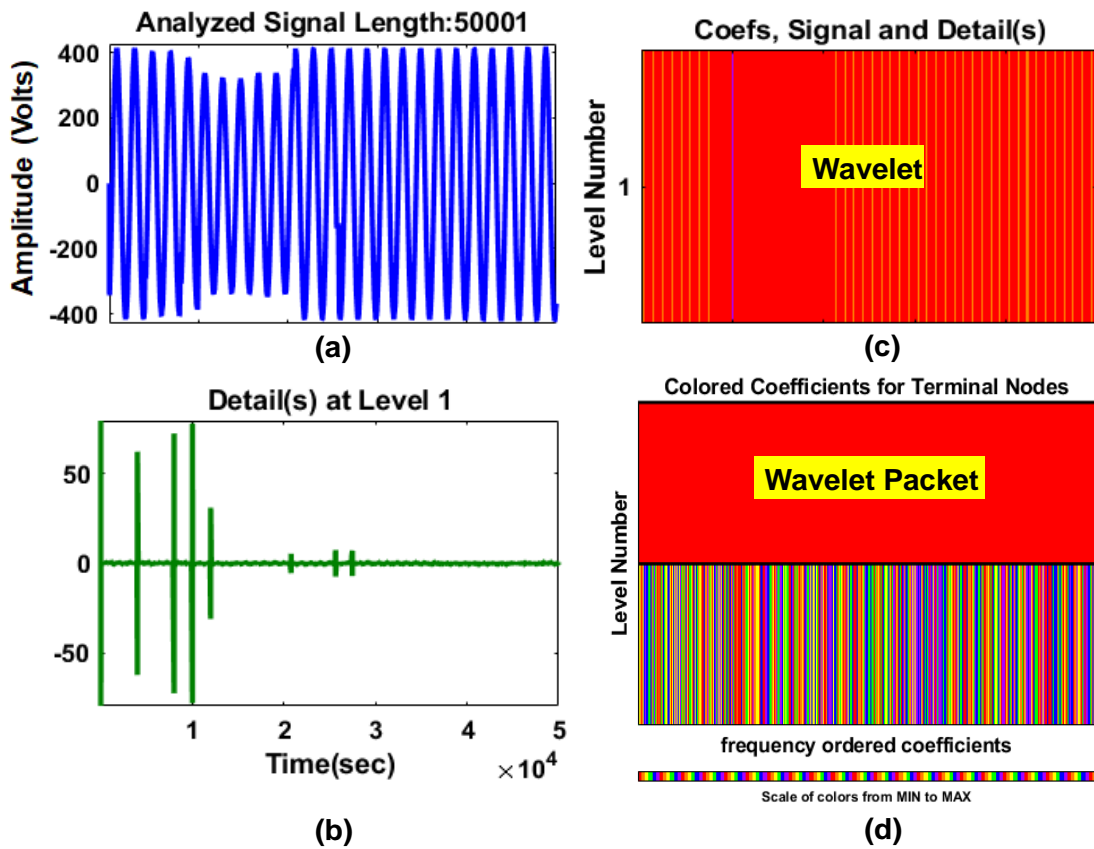

Fig. 8. LL fault (phase A) detection at PCC of cluster microgrid a) voltage signal b) detail coefficient c) contour plot of wavelet transform (WT) d) contour plot of wavelet packet transform (WPT)

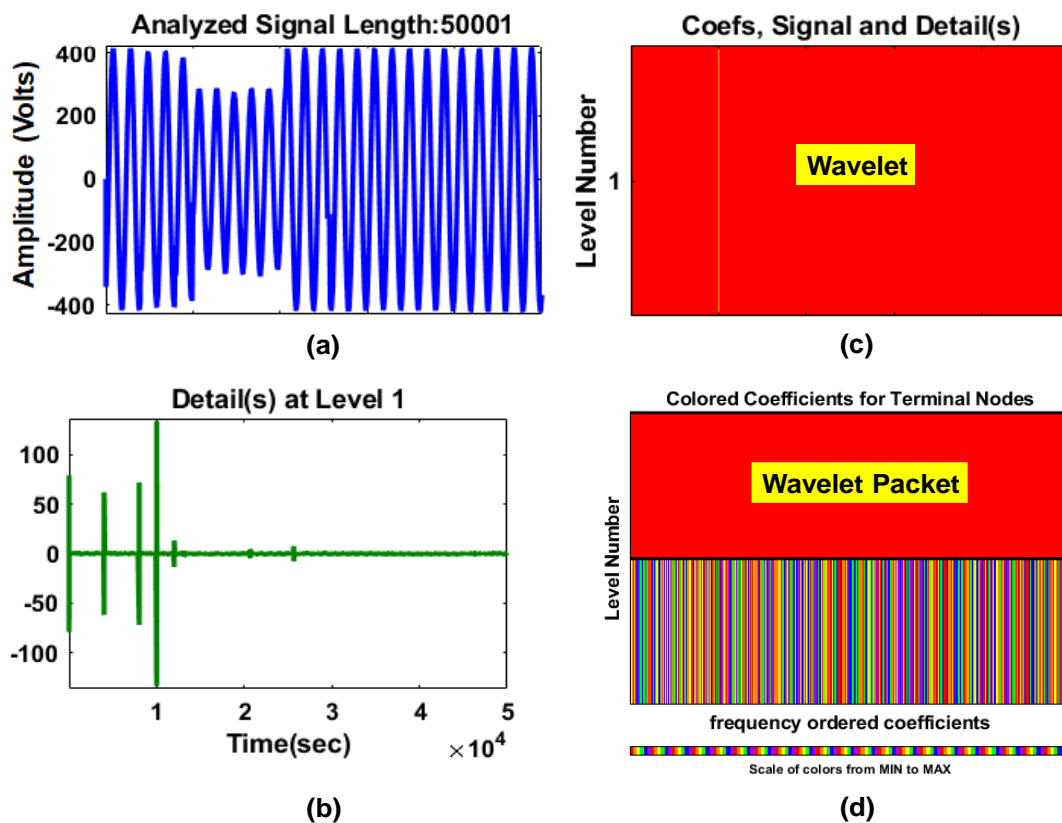

Fig. 9. LLG fault (phase A) detection at PCC of cluster microgrid a) voltage signal b) detail coefficient c) contour plot of wavelet transform (WT) d) contour plot of wavelet packet transform (WPT)

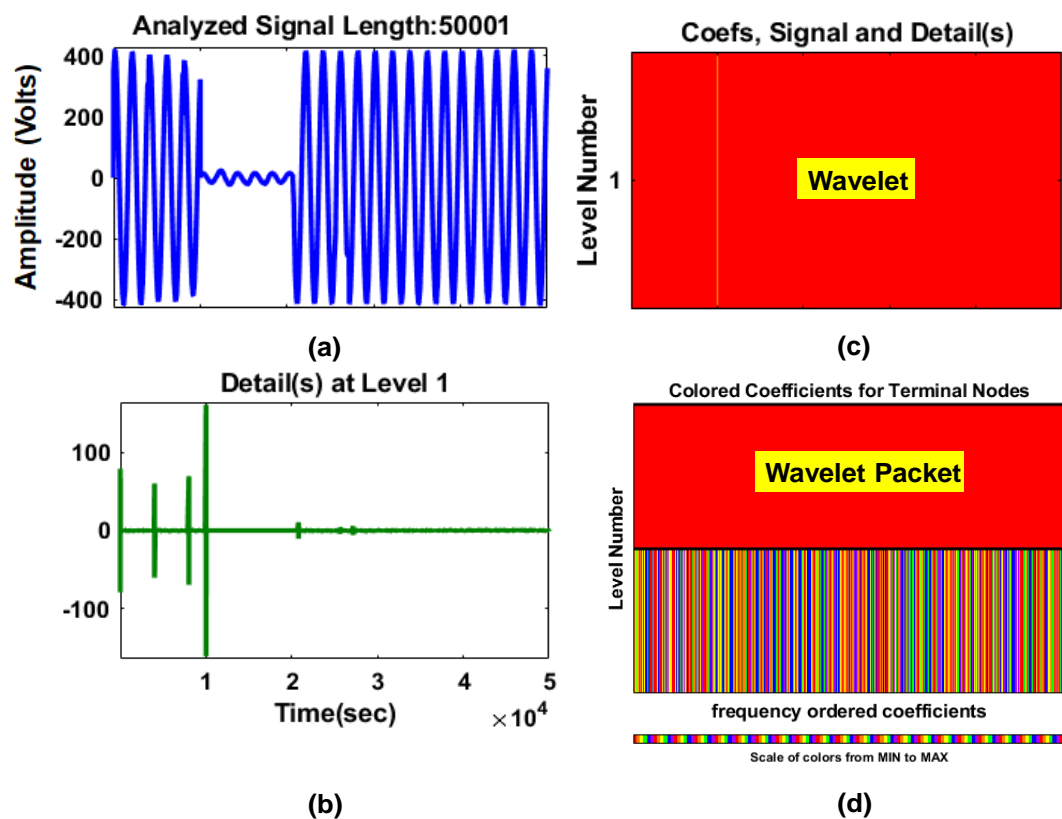

Fig. 10. LLL fault (phase A) detection at PCC of cluster microgrid a) voltage signal b) detail coefficient c) contour plot of wavelet transform (WT) d) contour plot of wavelet packet transform (WPT)

Table 2. Maximum values of detailed coefficients of in all phases using WT

Location of the fault	Type of the fault	Maximum coefficient of currents in phases R, Y, B and Ground			
		m (Phase-A)	n(Phase-B)	p(Phase-C)	q(Ground)
Location-1	3- Φ to Ground	51.3447	13.9434	55.9995	2.6059e-12
	3- Φ	51.3447	13.9351	55.9995	2.6064e-12
	Line-Line-Ground	51.3241	13.9858	54.9675	2.5988e-12
	Line-Line	50.3692	13.9415	57.9531	2.7653e-12
	Line-Ground	51.3652	18.5517	56.0004	2.4683e-12
Location-2	3- Φ to Ground	51.1448	13.9413	55.9995	2.6025e-12
	3- Φ	51.1448	13.9357	55.6735	2.5913e-12
	Line-Line-Ground	51.1225	13.9898	55.9672	2.6041e-12
	Line-Line	50.3696	13.9426	57.9528	2.7590e-12
	Line-Ground	52.9516	13.9025	56.8688	2.4354e-12
Location-3	3- Φ to Ground	51.3448	13.9431	55.9875	2.6047e-12
	3- Φ	51.3448	13.9352	55.9875	2.6003e-12
	Line-Line-Ground	51.3448	13.9865	55.9995	2.5997e-12
	Line-Line	50.3696	13.9416	57.9528	2.7417e-12
	Line-Ground	51.3640	13.9088	56.0039	2.4823e-12
Location-4	3- Φ to Ground	51.3448	13.9439	55.9996	2.6555e-12
	3- Φ	51.3448	13.9356	55.9996	2.6446e-12
	Line-Line-Ground	51.1448	13.9847	55.9994	2.6330e-12
	Line-Line	50.3699	13.9414	57.9526	2.6298e-12
	Line-Ground	51.3639	13.9145	56.0004	3.2478e-12
Location-5	3- Φ to Ground	47.0834	263.3394	48.1778	1.6195e-8
	3- Φ	47.0834	263.3460	48.1778	1.5469e-8
	Line-Line-Ground	47.0834	195.7122	55.9921	2.0820e-8
	Line-Line	51.3377	199.3076	48.1778	1.7592e-8
	Line-Ground	52.1332	199.3216	49.1457	1.9661e-8

Table 3. Comparison of performance indices of WT and WPT

Location of the fault	Performance parameter	LG fault	LL fault	LL-G fault	LLL fault
Location 1	Wavelet Transform				
	Standard Deviation	272.5	281.6	272.3	265.7
	Median Absolute	244.5	265.3	241.4	235.7
	Mean Absolute	220.6	231.9	225.3	198.5
	Entropy	285.2	302.7	320.7	318.4
	Wavelet Packet Transform				
	Standard Deviation	287.1	300.4	291.2	283.4
	Median Absolute	260.8	281.3	264.6	251.2
	Mean Absolute	238.4	248.4	245.2	224.2
	Entropy	299.4	317.3	331.2	326.3
Location 2	Wavelet Transform				
	Standard Deviation	282.5	282.2	278.3	280.5
	Median Absolute	264.2	275.8	261.2	255.1
	Mean Absolute	227.1	251.2	237.7	218.9
	Entropy	282.3	292.3	317.2	329.6
	Wavelet Packet Transform				
	Standard Deviation	297.3	302.5	302.1	296.3
	Median Absolute	279.7	291.8	277.4	273.2
	Mean Absolute	242.9	268.5	254.3	236.7
	Entropy	298.4	311.2	321.8	327.5

Location 3	Wavelet Transform				
	Standard Deviation	289.1	301.6	282.8	269.5
	Median Absolute	214.7	276.3	247.4	228.4
	Mean Absolute	245.2	247.9	236.5	221.2
	Entropy	297.5	312.4	302.8	307.5
	Wavelet Packet Transform				
	Standard Deviation	304.2	309.4	297.4	281.9
	Median Absolute	237.4	292.6	263.5	241.4
	Mean Absolute	259.9	262.5	252.5	236.9
Entropy	314.8	321.5	317.4	319.8	
Location 4	Wavelet Transform				
	Standard Deviation	277.1	321.6	272.3	265.7
	Median Absolute	234.5	295.3	241.4	235.7
	Mean Absolute	250.6	271.9	225.3	198.5
	Entropy	275.2	312.7	320.7	300.7
	Wavelet Packet Transform				
	Standard Deviation	289.3	345.5	287.3	285.6
	Median Absolute	248.8	307.4	259.9	249.5
	Mean Absolute	267.4	289.9	251.2	219.9
Entropy	293.2	321.5	335.2	327.4	
Location 5	Wavelet Transform				
	Standard Deviation	270.9	280.9	275.3	257.7
	Median Absolute	244.5	275.8	261.1	223.2
	Mean Absolute	240.6	251.8	245.2	208.1
	Entropy	305.2	312.4	310.5	295.3
	Wavelet Packet Transform				
	Standard Deviation	285.4	298.4	301.4	271.9
	Median Absolute	259.3	289.3	276.1	237.4
	Mean Absolute	254.5	267.6	261.5	223.5
Entropy	311.2	325.3	327.3	334.2	

Figures 9 and 10 show the simulation plots of the voltage signal passes through both WT and WPT when a double line fault (LL) and three phase fault (LLL) applied at 0.1 sec to 0.2 sec. Table 2 gives the information of maximum values of detailed coefficients of three phase currents in Location 1, Location 2, Location 3, Location 4 and Location 5 under various faults i.e. LG, LL, LL-G, LLL using Wavelet Transform. Similarly, all the results obtained from both WT and WPT in terms of the performance parameters such as standard deviation, median absolute deviation, mean absolute deviation and entropy are given in Table 3. From the obtained simulated results and quantitative results we proposed that wavelet packet transform is the best choice for detecting the various faults.

4.2. Case 2: Frequency response of cluster microgrid under faulted conditions

The intended system is currently in grid connected/islanded operation. In this scenario, we measured the system's frequency response with static and dynamic loads by imposing a fault at the cluster microgrids PCC for the duration of 0.1sec to 0.3sec. The grid frequency is retained at the standard frequency levels with a settling time of 0.4 seconds and a minimum frequency deviation of 0.1 percent shown in Fig. 11(a) as defined by IEEE standard 1159-2009. When dynamic loads are applied in the duration of t=0sec to 0.3sec, substantial changes in the frequency

response are detected, but the system keeps the normal frequency at a settling time of 0.58sec and with a deviation of 0.15 percent, as shown in Fig. 11(b).

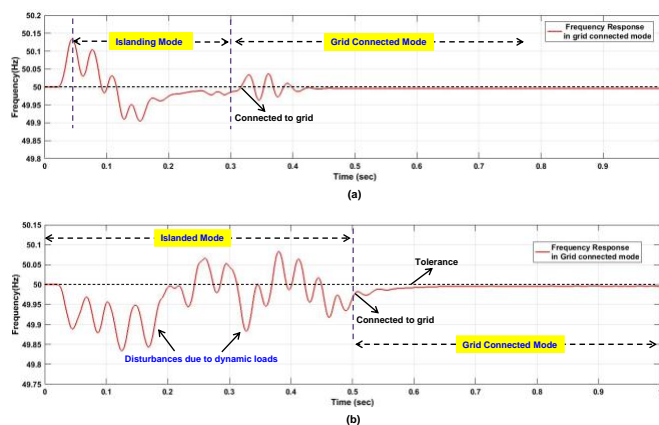

Fig. 10. Frequency characteristics of proposed system under islanded condition for a) static loads b) dynamic loads

5. Conclusion

The main objective of this paper is to propose a cluster microgrid system which employ WT and WPT techniques to detect and identify the different faults. The proposed methodologies WT and WPT are applied to the high-frequency components which are introduced by distributed

generator based on power electronic inverters at the PCC. High frequency components are time and frequency localized. The proposed WT and WPT would characterize and also diagnose the fault disturbances by examining the fluctuation of contours and the performance parameters such as standard deviation, median absolute, mean absolute, and entropy. As illustrated in the different test cases presented in Section 4, it is observed that WPT is a technique performs better when compared with various operating conditions such as no-noise, 40-dB noise. Whenever the noise level in the voltage function crosses 40 dB, both methods are failed to extract geometric features for disturbance detection in no-noise circumstances. As a result, it's been discovered that WPT is more effective and reliable at detecting disturbances in the aforementioned operating conditions.

Appendix-A

The modeling parameters of all the renewable sources used in the individual microgrids are listed in the following table.

Parameter used for modeling	Specification
Solar PV irradiance	200 kW/m ² -1000kW/m ²
Solar PV temperature	25 ⁰ c-50 ⁰ c
Wind turbine @ base power	1100VA
Wind speed	15m/s
Normal voltage of the batter	90V
Rated capacity of the battery	7.5Ah
No. of fuel cell	85
Temperature of the stack	343.5K
Duty ratio of the converter	0.8
Switching frequency of the converter	100kHz
Ground resistance	80 ohm
Power Transformer	350kVA, 0.415/11kV
Transformer frequency	50Hz
Length of the transmission line	15km
Fault resistance	0.001ohm
Main grid voltage	11000V
Frequency	50Hz
Threshold value	40

References

- [1] S. N. V. B. Rao, Y. V. P Kumar, D. J. Pradeep, C. P. Reddy, A. Flah, H. Kraiem, J. F. Al-Asad, "Power Quality Improvement in Renewable-Energy-Based Microgrid Clusters Using Fuzzy Space Vector PWM Controlled Inverter", *Sustainability*, vol. 14, No. 8, 2022.
- [2] L. Bagherzadeh, H. Shahinzadeh, G. B. Gharehpetian, "Scheduling of Distributed Energy Resources in Active Distribution Networks Considering Combination of Techno-Economic and Environmental Objectives", *International Power System Conference (PSC)*, pp. 687-695, 2019.
- [3] Md. Shahidehpour, Zhiyi Li, M. Gnaji, "Smart cities for a sustainable urbanization", *IEEE Electrification magazine*, June 2018.
- [4] F.Ayadi, I. Colak, B. Ramazan,"Interoperability in smart grids", *IEEE conference on Smart Grid*, 9-11 Dec. 2019.
- [5] S. N. V. B. Rao, K. Padma,"A Review on Schemes for Interconnecting Microgrids of Urban Buildings", *Microelectronics, Electromagnetics and Telecommunications, Lecture Notes in Electrical Engineering*, vol. 655. Springer, 2021.
- [6] H. Shahinzadeh, S. Nikolovski, J. Moradi, R. Bayindir, "A Resilience-Oriented decision making model for the operation of smart micro grids subject to Techno-Economic and Security Objectives",*International Conference on Smart Grid (icSmartGrid)*, pp. 226-230, 2021.
- [7] K. Naraghipour, K. Ahmed and C. Booth, "New Islanding Detection Method With Voltage Amplitude Variation for Inverter-based Distributed Generator," *9th International Conference on Smart Grid (icSmartGrid)*, 2021, pp. 243-248.
- [8] A. Raza, A. Benrabah, T. Alquthami, M. Akmal,"A Review of Fault Diagnosing Methods in Power Transmission Systems", *Applied Sciences*, vol. 10, No. 4, 2020.
- [9] Gaurav Kapoor,"Wavelet transform based fault detector for protection of series capacitor compensated three phase transmission line", *International Journal of Engineering, Science and Technology*, vol. 10, No. 4, pp. 29-49, 2018.
- [10] K. Basanta Panigrahi, Prakash K. Ray, P. K. Rout, A. Mohanty, Kumaresh Pal, "Detection and classification of faults in a microgrid using wavelet neural network", *Journal of Information and Optimization Sciences*, vol. 39, No.1, 327-335, 2017.
- [11] Zuoxun Wang, Liqiang Xu, "Fault Detection of the Power System Based on the Chaotic Neural Network and Wavelet Transform", *Complexity*, vol. 2020.
- [12] S. Baloch, S. S. Samsani and M. S. Muhammad, "Fault Protection in Microgrid Using Wavelet Multiresolution Analysis and Data Mining," *IEEE Access*, vol. 9, pp. 86382-86391, 2021.
- [13] R. Escudero, J. Noel, J. Elizondo, J. Kirtley, "Microgrid fault detection based on wavelet transformation and Park's vector approach", *Electric Power Systems Research*, vol. 152, pp. 401-410, 2017.
- [14] Lee C-Y, Cheng Y-H., "Motor Fault Detection Using Wavelet Transform and Improved PSO-BP Neural Network". *Processes*. Vol. 8, No. 10, 2020.
- [15] G. Bayrak,"Wavelet transform-based fault detection method for hydrogen energy-based distributed generators", *International Journal of Hydrogen Energy*,vol. 43, No. 44, pp. 20293-20308, 2018.

- [16] S.S. Gururajapathy, H. Mokhlis, H.A. Illias, "Fault location and detection techniques in power distribution systems with distributed generation: A review", *Renewable and Sustainable Energy Reviews*, vol 74, pp. 949-958, 2017.
- [17] P. Balakrishnan, S. Gopinath, "A new intelligent scheme for power system faults detection and classification: A hybrid technique", *International Journal of Numerical Modeling*. vol. 33, 2020.
- [18] Y. Bansal, R. Sodhi, "Microgrid fault detection methods: Reviews, issues and future trends", *IEEE Innovative Smart Grid Technologies - Asia (ISGT Asia)*, pp. 401-406, 2018.
- [19] F. Zhang, L. Mu, "A Fault Detection Method of Microgrids With Grid-Connected Inverter Interfaced Distributed Generators Based on the PQ Control Strategy," *IEEE Transactions on Smart Grid*, vol. 10, no. 5, pp. 4816-4826, 2019.
- [20] R. Fahim, K. Sarker S, Muyeen SM, Sheikh MRI, Das SK., "Microgrid Fault Detection and Classification: Machine Learning Based Approach, Comparison, and Reviews", *Energies*, vol. 13, no. 13, 2020.
- [21] Y. P. kumar, S. Debnath, S. Paul, "Microgrid fault detection technique using phase change of Positive sequence current", *International Journal of Modelling and Simulation*, vol. 14, No.1, 2022.
- [22] K. M. Lee, C.W. Park, "New Fault Detection Method for Low Voltage DC Microgrid with Renewable Energy Sources", *Journal of Electrical Engineering and Technology*, 2022.
- [23] K. Saleh, H. Ali, E. F. El-Saadany, "Fault detection and location in medium-voltage DC microgrids using travelling-wave reflections", *IET Renewable Power Generation*, vol. 14, No. 4, pp. 571-579, 2020.
- [24] S. N. V. B. Rao, K. Padma, Y. V. P. Kumar, "Implementation of minigrid with hybrid renewable energy sources for urban community buildings," *Inter. Journal of Recent Technology and Engineering*, vol. 8, no. 4, 2019.
- [25] Hong Y-Y, Wei Y-H, Chang Y-R, Lee Y-D, Liu P-W. "Fault Detection and Location by Static Switches in Microgrids Using Wavelet Transform and Adaptive Network-Based Fuzzy Inference System", *Energies*, vol. 7, No. 4, pp. 2658-2675, 2014.
- [26] Prakash K. Ray, Basanta K. Panigrahi, Pravat K. Rout, Asit Mohanty, Foo Y. S. Eddy & Hoay Beng Gooi, "Detection of Islanding and Fault Disturbances in Microgrid using Wavelet Packet Transform", *IETE Journal of Research*, vol. 65, No. 6, pp. 796-809, 2019.
- [27] N. Altin and S. E. Eyimaya, "A Review of Microgrid Control Strategies", *International Conference on Renewable Energy Research and Application (ICRERA)*, pp. 412-417, 2021.
- [28] O. Aissa, S. Moulahoum, B. Babes, I. Colak, "Power Quality Enhancement of AC/DC Converter by a Smart Direct Power Control: Practical Assessment," *2021 10th International Conference on Renewable Energy Research and Application (ICRERA)*, pp. 203-209, 2021.