

# Analysis of Three-Phase Shunt Active Filter under Wide Range of Load Conditions

Chegudi Rangarao\*<sup>‡</sup>, Balamurugan Ramadoss\*\*<sup>‡</sup>, RamaKoteswara Rao Alla\*\*\*<sup>‡</sup>

\*Research Scholar, Department of Electrical Engineering, Annamalai University, Chidambaram, Tamilnadu, India.

\*\*Associate Professor, Department of Electrical Engineering, Annamalai University, Chidambaram, Tamilnadu, India.

\*\*\*Associate Professor, Department of EEE, RVR & JC College of Engineering, Andhra Pradesh, India.

(rangarao.chegudi@gmail.com, bala\_aucdm@yahoo.com, ramnitkkr@gmail.com)

<sup>‡</sup>Corresponding Author; Chegudi Rangarao, Assistant Professor, Department of Electrical and Electronics Engineering, RVR & JC College of Engineering, Guntur, Andhra Pradesh-522019, India, Tel: +90 8106153781, rangarao.chegudi@gmail.com.

*Received: 02.09.2022 Accepted: 14.10.2022*

**Abstract-** In this work, three phase shunt active power filter (SAPF) under wide range of loading conditions by using different Pulse width Modulation techniques has been done. Power Quality (PQ) is an essential concern in the current scenario due to the regular use of power electronic converters and non-linear loads. PQ issues have a significant negative financial influence on consumers and utilities. The main aim of the work is minimization of Total Harmonics Distortion (THD) in medium and higher power applications with respect to the wide range of loading conditions. Performance analysis of a three-phase shunt active filter under a wide range of load conditions has been considered in this paper. For the designed controller analysis, the loads R, RL, RC, and RLE are taken into account along with various pulse width modulation (PWM) control approaches and the proportional-integral (PI) controller. Additionally, a comparison is made between traditional PWM with PI, space vector pulse width modulation (SVPWM), and selective harmonic elimination (SHE) PWM-PI control. System performance has been judged using Total Harmonic Distortion. The simulation results clearly show that the THD generated by the offered PWM schemes and PI controllers meets with the recommended standard set by IEEE 519. MATLAB/Simulink has been used to simulate and test the system. Finally, the performance of the proposed system is compared to the other research findings to claim the effectiveness of the system.

**Keywords-** Shunt active filter, PI, PWM, SVPWM, SHE PWM, THD.

## List of Abbreviations:

SAF – Shunt Power Filters  
CSI - Current Source Inverters  
PQ – Power Quality  
PI – Proportional Integral  
PWM – Pulse Width Modulation  
PCC - Point of Common Coupling  
SVPWM – Space Vector Pulse Width Modulation

SPWM – Sinusoidal Pulse Width Modulation  
SHE-PWM – Selective Harmonic Elimination PWM  
THD - Total Harmonic Distortion  
UPS - Uninterruptible Power Sources  
VSI - Voltage source Inverters

## 1. Introduction

Maintaining the electrical power quality given to the network of connected sensitive loads is crucial in today's technological age. The maintaining of quality of power is very difficult because many types of equipment are connected to the electrical networks at as nonlinear loads which make power quality issues in the distribution network. The nonlinear loads such as Electronic equipment, controlled

rectifiers, variable frequency motors, induction arc furnaces, and other commercial and home appliances[1]. The above mentioned loads are acting as non-linear loads which produced harmonics when they switch, which increases the amount of reactive power used and, in turn, lowers power factor, which increases electrical system losses [2]. Several factors, including current and voltage harmonics from static power electronics converters, zero and negative sequence components from single-phase, reactive power, unbalanced loads, voltage sag, flicker, voltage swell, and voltage

interruption, are causing the quality of the country's electricity supply to decline. The consequence of harmonics is mitigated by the various filtering techniques namely passive and active filter techniques[3]. The system becomes bulky due to the employment of passive filtering techniques, resonance between the transmission line, line impedance, and the switching of passive elements, which all contribute to a spike in voltage [4]. To overcome the problems of passive filter, active filtering technique can be applied to the distribution network for mitigation of harmonics generated by the non-linear loads and it is more efficient compensation techniques in the power system network [5]. Harmonic currents in the system can have negative impacts on the load of other customers at the Point of Common Coupling (PCC), as well as cause excessive motor heating, plant malfunction, low power factor, etc.[6,7].

The current harmonics, reactive power detection system, and compensation control algorithm are the sole determinants of the shunt active filter (SAF)'s ability to reduce harmonics [8]. Various current control techniques can be adapted by the researcher for mitigation of current harmonics [9]. Generally, Proportional Integral (PI) controller [10] is prepared to dampen the effects of current harmonics generated by system. It has certain shortcomings include its inability to compensate for harmonics satisfactorily, as well as the need to fine-tune the controller's parameters manually. To solve the complexity of PI controller, a hysteresis controller has been applied. This controller behaves fast response for the dynamic behaviors but same time accuracy of the system may be affected with frequency [11]. Further, repetitive controller has been developed for mitigation of harmonics, but it is poor control on sudden changing of load [12]. The aim of a predictive deadbeat PI-based control for SAF applications is to improve harmonic reduction in a distribution network [13]. The authors of proposed a Kalman filter-based PI controller to handle power quality issues; however, the Kalman filter is developed with steady-state and dynamic model behavior in mind. However, it is challenging to manage uncertainty in the system, thus it is important to develop robust controllers [14, 15]. Nonlinear applications rely heavily on robust controllers because of the uncertainty and disruptions they introduce.

For SAF control, three fundamental PWM techniques such as carrier-based PWM, space-vector PWM, and PWM with selective harmonic elimination schemes have been used [16]. For a carrier-based PWM modulator, the performance metrics that matter are those that can be derived from the modulation signals. When a sinusoidal modulating signal is compared to a triangular signal with two edges or a saw tooth signal with a single edge, the resulting signal is the SPWM. In most cases, the carrier frequency will be significantly

higher than the modulating signal. SVPWM dominates the market because of its ease of implementation in both hardware and software, as well as its respectable performance at low modulation ratios. When the converter's levels are high, however, achieving the SVPWM becomes extremely challenging. SVPWM allows for more than just the four switching states available with carrier-based PWM in multilevel inverters. Compared to carrier-based PWM [17], Space Vector PWM provides greater flexibility in selecting switching states. When using carrier-based PWM mode, the modulated output voltage is often smooth and distorted.

Passive filters have a low signal gain since there is no amplifying component in them. As a result, the filter circuit's output receives a signal that is somewhat weaker than the applied input signal. Active filters can offer high input impedance and low output impedance, which makes their characteristics independent of the source and load impedances. Among the PWM techniques, SHE-PWM is an efficient control technique for the reduction of harmonics especially in medium and high power applications [18]. In addition to these, SHE-PWM technique is produced higher operating efficiency, low switching losses and less filtering requirement when compared to the other PWM techniques. In this proposed work, for mitigation of harmonics generated by the non-linear loads, sine, SVPWM and SHE-PWM techniques have been proposed to maintain THD indices recommended by IEEE 519 standard. Furthermore, results of various PWM techniques compared with other research findings. This research work presents the performance comparison of a three-phase shunt active filter using various PWM techniques and also under various load conditions and its design process is shown in Fig. 1.

### Contributions

- ✓ Simulation work of SAF is carried out by different PWM techniques for the reduction of harmonics generated by nonlinear loads.
- ✓ In order to evaluate the performance of the various PWM techniques, the proposed system is subjected to various loading conditions. (R, RL, and RLE loads)
- ✓ A comparative analysis is made with respect to the THD with different PWM techniques.

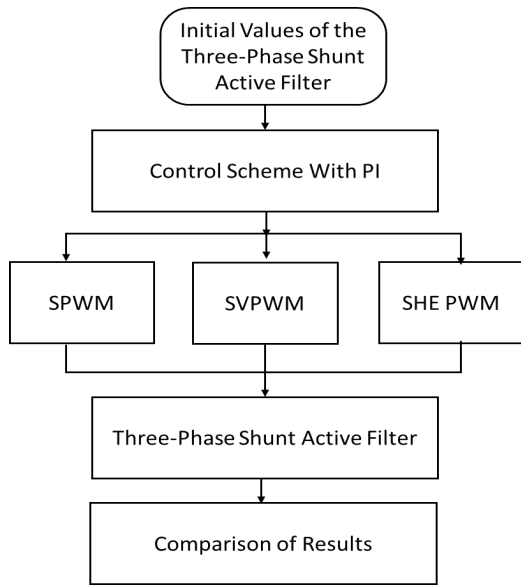

Fig.1. Procedure of SAF design

2. Modelling of SAF and Control Schemes

In order to increase the power quality, many filters were used. Passive elements (L and C) or active components such as solid-state Voltage source Inverters (VSI) and Current Source Inverters may be used to get rid of the harmonic, which can then be removed (CSI). It is hypothesized in this study that a hybrid active power filter can reduce harmonics while also balancing non-linear loads. This Shunt Active Filter is a device that is shunt-connected and is based on a voltage-sourced converter (VSC) [19]. This SAF has the capability of injecting reactive power into the power system. It does this by injecting a current of variable magnitude that is in quadrature with the line voltage. This work describes an implementation of a simple and innovative control approach of a shunt active filter (AF) for ac voltage regulation at load terminals (at PCC), removal of harmonics, correction of power factor, and load balancing of nonlinear loads as shown in Fig.2.

The AF control strategy has been made adjustable so that it may be changed to offer power-factor correction (unity), remove harmonics, and balance the load on nonlinear loads. The control method that has been developed provides the AF with an inbuilt dc bus that is capable of providing its own support. The shunt AF in this design is an insulated-gate bipolar transistor (IGBT)-based current controlled voltage source inverter (CC-VSI) with a dc bus capacitor.

2.1. Modelling of SAF

By applying an abc to dq0 transformation in a synchronous rotating frame, the performance of a balanced three-phase device can be more easily assessed. From the

abc-reference frame, the dq-frame rotates with an angle of  $\theta = \omega t$  around its own reference axis. Here is the step-by-step transformation from d and q coordinates:

$$\begin{bmatrix} V_d \\ V_q \\ V_0 \end{bmatrix} = K \begin{bmatrix} V_a \\ V_b \\ V_c \end{bmatrix} \tag{1}$$

$$K = \sqrt{\frac{2}{3}} \begin{bmatrix} \cos\theta & \cos(\theta - \frac{2\pi}{3}) & \cos(\theta + \frac{2\pi}{3}) \\ \sin\theta & \sin(\theta - \frac{2\pi}{3}) & \sin(\theta + \frac{2\pi}{3}) \\ \frac{1}{\sqrt{2}} & \frac{1}{\sqrt{2}} & \frac{1}{\sqrt{2}} \end{bmatrix} \tag{2}$$

Each stage of the SAF in Fig. 2. can be modelled mathematically as follows:

$$\left. \begin{aligned} L_f \frac{di_{fa}}{dt} &= -R_f i_{fa} + V_{fa} - V_{La} \\ L_f \frac{di_{fb}}{dt} &= -R_f i_{fb} + V_{fb} - V_{Lb} \\ L_f \frac{di_{fc}}{dt} &= -R_f i_{fc} + V_{fc} - V_{Lc} \end{aligned} \right\} \tag{3}$$

Equation (1) can be derived from equations (2) and (3) using the following format:

$$L_f \frac{di_f}{dt} \begin{bmatrix} i_{fa} \\ i_{fb} \\ i_{fc} \end{bmatrix} = -R_f \begin{bmatrix} i_{fa} \\ i_{fb} \\ i_{fc} \end{bmatrix} + \begin{bmatrix} V_{fa} \\ V_{fb} \\ V_{fc} \end{bmatrix} - \begin{bmatrix} V_{La} \\ V_{Lb} \\ V_{Lc} \end{bmatrix} \tag{4}$$

From equation (4), the dq-transformation is given by,

$$L_f \frac{di_f}{dt} \left( K^{-1} \begin{bmatrix} i_{fa} \\ i_{fb} \\ i_{fc} \end{bmatrix} \right) = -R_f K^{-1} \begin{bmatrix} i_{fa} \\ i_{fb} \\ i_{fc} \end{bmatrix} + K^{-1} \begin{bmatrix} V_{fa} \\ V_{fb} \\ V_{fc} \end{bmatrix} - K^{-1} \begin{bmatrix} V_{La} \\ V_{Lb} \\ V_{Lc} \end{bmatrix} \tag{5}$$

From the above equations,

$$\frac{d}{dt} K^{-1} = \omega \sqrt{\frac{2}{3}} \begin{bmatrix} -\sin\theta & \cos\theta & 0 \\ -\sin(\theta - \frac{2\pi}{3}) & \cos(\theta - \frac{2\pi}{3}) & 0 \\ -\sin(\theta + \frac{2\pi}{3}) & \cos(\theta + \frac{2\pi}{3}) & 0 \end{bmatrix} \tag{6}$$

$$K \frac{d}{dt} K^{-1} = \omega \begin{bmatrix} 0 & 1 & 0 \\ -1 & 0 & 0 \\ 0 & 0 & 0 \end{bmatrix} \tag{7}$$

$$\frac{d\theta}{dt} = \omega \tag{8}$$

Applying all the above relations in equation (5),

$$\frac{di_f}{dt} \begin{bmatrix} i_{fa} \\ i_{fb} \\ i_{fc} \end{bmatrix} = \begin{bmatrix} -\frac{R_f}{L_f} & \omega & 0 \\ -\omega & -\frac{R_f}{L_f} & 0 \\ 0 & 0 & -\frac{R_f}{L_f} \end{bmatrix} \begin{bmatrix} i_{fa} \\ i_{fb} \\ i_{fc} \end{bmatrix} + \frac{1}{L_f} \begin{bmatrix} V_{fa} \\ V_{fb} \\ V_{fc} \end{bmatrix} - \frac{1}{L_f} \begin{bmatrix} V_{La}} \\ V_{Lb} \\ V_{Lc} \end{bmatrix} \tag{9}$$

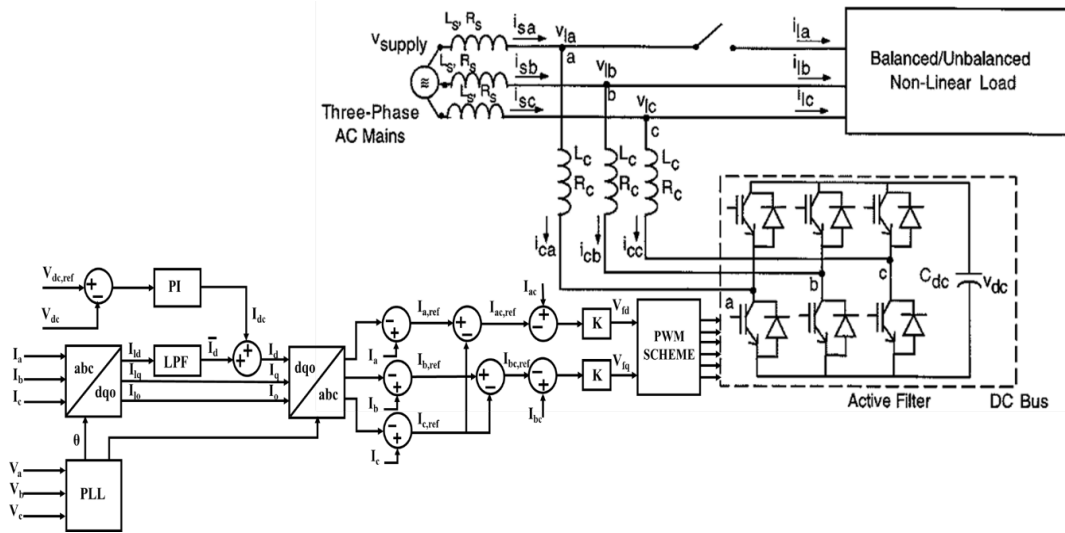

Fig.2. Structure of three-phase shunt active power filter

The SAPF's output voltage can be represented as

$$\left. \begin{aligned} V_{fd} &= MV_{dc} \cos\alpha \\ V_{fq} &= MV_{dc} \sin\alpha \end{aligned} \right\} \quad (10)$$

The bus voltage is preceded by the SAPF output voltage at the phase angle at which  $V_{dc}$  is the DC-link voltage. The peak phase-to-neutral voltage on the AC side and the DC voltage are connected by the factor M.

$$\frac{d}{dt} \begin{bmatrix} i_{fa} \\ i_{fb} \end{bmatrix} = \begin{bmatrix} -\frac{R_f}{L_f} & \omega & \frac{M \cos\alpha}{L_f} \\ \omega & -\frac{R_f}{L_f} & \frac{M \sin\alpha}{L_f} \end{bmatrix} \begin{bmatrix} i_{fd} \\ i_{fq} \\ V_{dc} \end{bmatrix} - \frac{1}{L_f} \begin{bmatrix} V_{Ld} \\ V_{Lq} \\ V_{L0} \end{bmatrix} \quad (11)$$

The voltage on the DC-link capacitor steadily drops over time due to switching losses in the voltage source inverter. To keep that operational voltage, SAPF draw the required amount of current from the utility source.  $I_{c,abc}$  and  $i_{loss,abc}$  are the current and switching loss, respectively.

$$i_{f,abc} = i_{c,abc} + i_{loss,abc} \quad (12)$$

To make certain that the power source only sends active current to the load, it is SAPF's responsibility to deliver the appropriate current components.

### 2.2. Sinusoidal Pulse Width Modulation (SPWM)

To create the carrier signal, a sine PWM modulator adds the modulation signal. Thus, in each period of the carrier signal, the two legs of the converter alternate between supplying the positive and negative rails. Referring to [15, 16], if the reference signal is higher than the carrier signal, the corresponding active device is turned on; otherwise, it is turned off. The evolution of the carrier - based PWM approach is depicted in Fig. 3.

In this case, the modulation signals are responsible for the significant performance of a carrier-based PWM modulator. The effect of a carrier, however, on the modulator's excellent performance is studied in [17–19]. A triangle signal with double edges, a saw tooth signal with a single edge carrier signal, and a sinusoidal modulating signal are contrasted to produce the PWM signal. [20] maintains the carrier frequency substantially more compared to the frequency of the modulating signal.

### 2.3. Space Vector Pulse Width Modulation

SVPWM dominates the market because it is easy to implement in both hardware and software while still providing respectable performance at low modulation ratios. The SVPWM, however, becomes very difficult to accomplish as converter levels rise. SVPWM allows for more than the four switching states available with carrier - based PWM in multilayer inverters [25]. As a rule, Space Vector PWM provides greater leeway in switching state selection than carrier based PWM. To a large extent, the modulated output voltage in carrier-based PWM mode is not perfectly clean. With a high number of levels and multilayer inverters to manage them, this carrier-based PWM approach might be useful. When using a multi-level inverter, it is best to use one that has a set number of switches and uses pulse width modulation appropriately. For inverters that need to handle lots of power at once, the PWM approach that uses the least amount of common mode voltage is the carrier based PWM technique. Therefore, care must be taken in selecting these SVPWM switches, as detailed in [21-24]. Since it employs nonlinear elements, the multi-level converter may be classified as a nonlinear controller.



start. The lowest non-triple harmonic components of a system with three phases are filtered out. Most of the time, the 120 electrical degree phase shift characteristic will be used to eliminate all triple-harmonics in line-to-line voltage.

### 3. Control of SAF

To regulate the Shunt Active Filter, a control approach is needed that generates a pulse that is modulated by a pulse width modulator (PWM) (Inverter). It has been measured by collecting the current from the shunt converter and the receiving end's load current. Both currents from the three-phase system have been transformed into currents along the dq0 axis. This dq0-axis provides information on the active, reactive, and reference components of the three-phase currents in the appropriate order. In order to have a better understanding of the controller's and SAF's performance, the simulation model includes multiple load fluctuations that are generated at varying intervals. Comparisons have been performed between the variations in the reactive components of the converter current and the load current as well as the variations in the inactive components of the load current and the shunt converter current. It can be able to identify the accessible active and reactive component currents through this comparison. The control structure of SAF is given in Fig. 4. In three-phase shunt Active filter circuit, the selection of DC voltage reference, capacitor selection and filter inductor selection are more important. These values are selected based on the load current magnitude with non-linear loads such as, R, RL and RLE before connecting the SAF. There are many researcher explained the optimal selection of these circuit parameters of SAF. Particularly, The reactive power needs of the system and harmonic cancellations are the two key factors that may be used to determine the value of the filter's inductance. Similarly the based upon the settling time, response time and variation in  $V_{DC}$  the final value of capacitor is selected.

It has been determined that the ideal values for  $K_p$  and  $K_i$  are 0.2 and 10, respectively. It can be tuned on the basis of the frequency domain or time domain analysis tools available in the MATLAB simulation. There are many methods such as Ziegler Nichols, internal model control based tuning methods are used to fix the optimal values of the gains in PI controller. After connecting the shunt active filter, the harmonics distortion was significantly cut down, as shown by the results.

The PI controller is tuned by traditional Ziegler Nicols method and also using internal model controller as presented in [25]. The pulse width modulation (PWM) signal is

produced when the resulting dq0 component is transformed into a three-phase (abc) component as shown in Fig. 4. A discrete PWM block is used in order to effect the transformation of this three-phase (abc) component into a PWM signal. The graphic illustrates the pulse width modulation signal with a frequency of 10 kHz. This signal is used to regulate the SAF converter so that compensating current may be injected. This will not only ensure that the voltage remains stable, but it will also remove any harmonics that may be present in the proposed system.

### 4. Results and Discussions

This Simulink model illustrates the three-phase supply system connected to non-linear loads, such as a diode bridge rectifier with an R, RL, and RLE load. Multiple currents will be drawn from the system at different times as a result of the non-linear load characteristics. As seen in Fig. 5, the system's introduction of harmonics is also due to this non-linear load. The power factors at the source will be quite low as a result.

The simulation study has been carried out for the different loads such as R, RL and RLE loads at different intervals. The Fig. 6. shows the simulation results of PI-SPWM controller results. Where, R load is connected from 0.12 sec to 0.2 sec and RL is connected at 0.25 sec to 0.35 sec and RLE load is connected from 0.4 sec to remaining time period.

From the results, it has been observed that the PI-SPWM controls the SAF and have oscillation in the load current waveform. The THD of the current waveform is analyzed for PI-SPWM and has 9.73% THD content in the output as shown in Fig. 7 of THD spectrum.

For the similar to the pervious load conditions, PI-SVPWM is applied to the control scheme and SAF and maintain the load current closure to sinusoidal during load variation as shown in Fig. 8.

But the magnitude of odd order harmonics are higher in the load current and has a THD of 8.98% as shown in Fig. 9. As demonstrated in Fig. 10, the SAF with PI-SHE PWM selects the proper compensation current and aligns with the load current to keep the source current as close to sinusoidal as is practicable. The THD has also been brought down to 3.5%, and the consequences may be seen in Fig. 11.

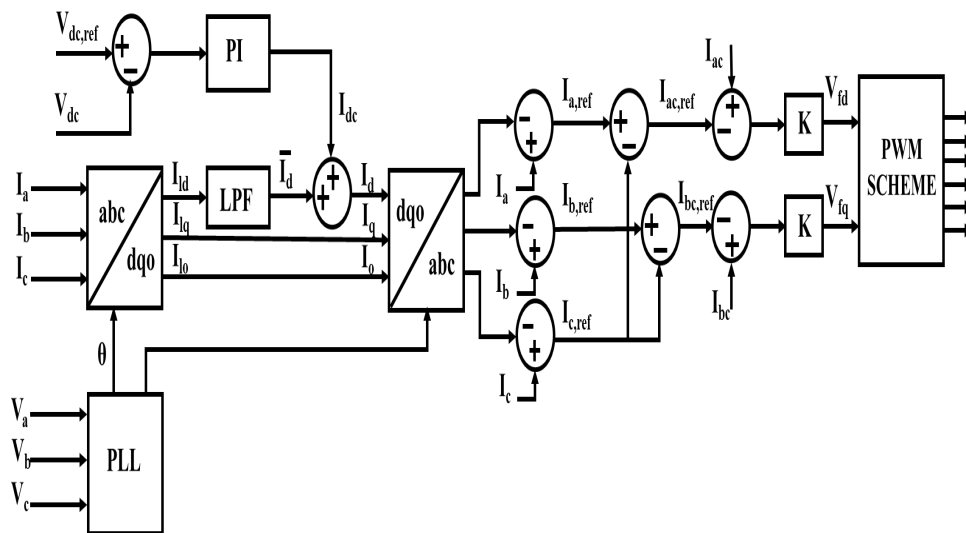

Fig. 4. Control Scheme for Three-phase shunt active filter

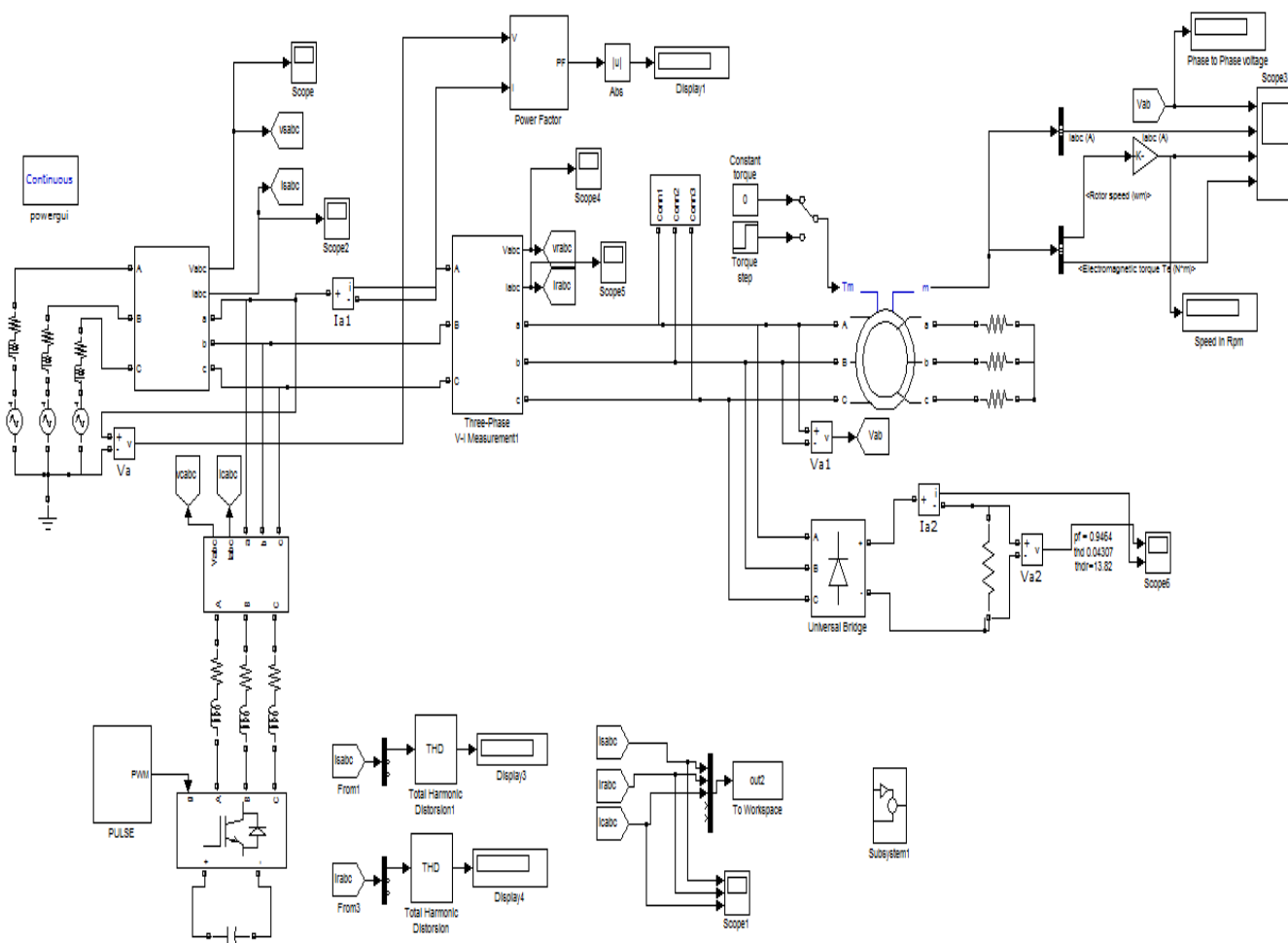
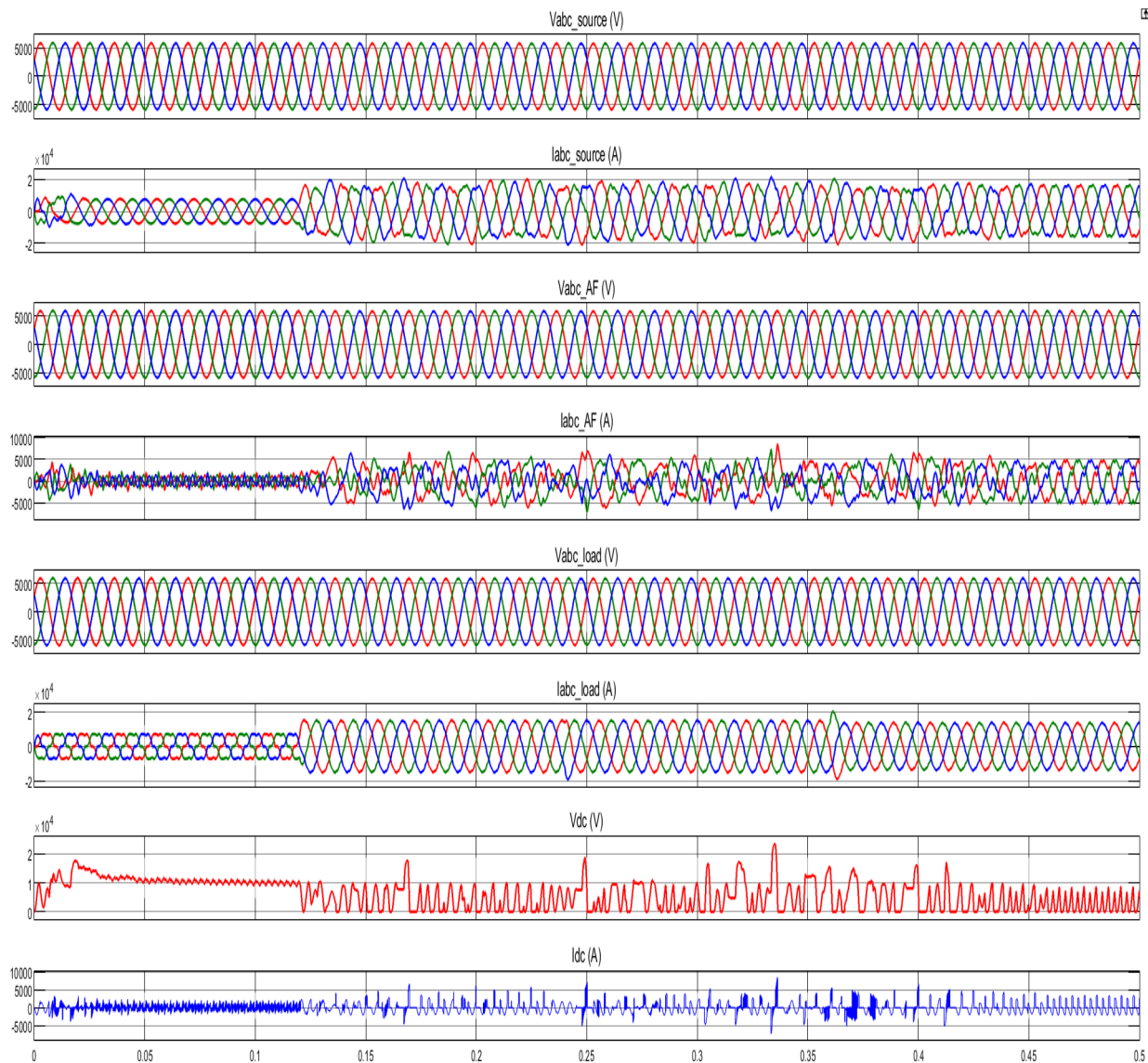
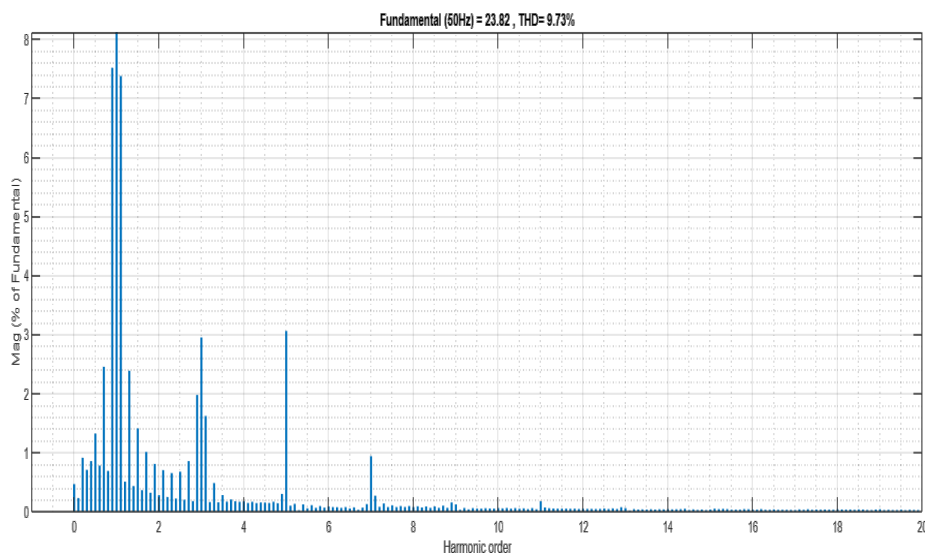

Fig. 5. Simulation model of Shunt Active Filter with Non-Linear Loads

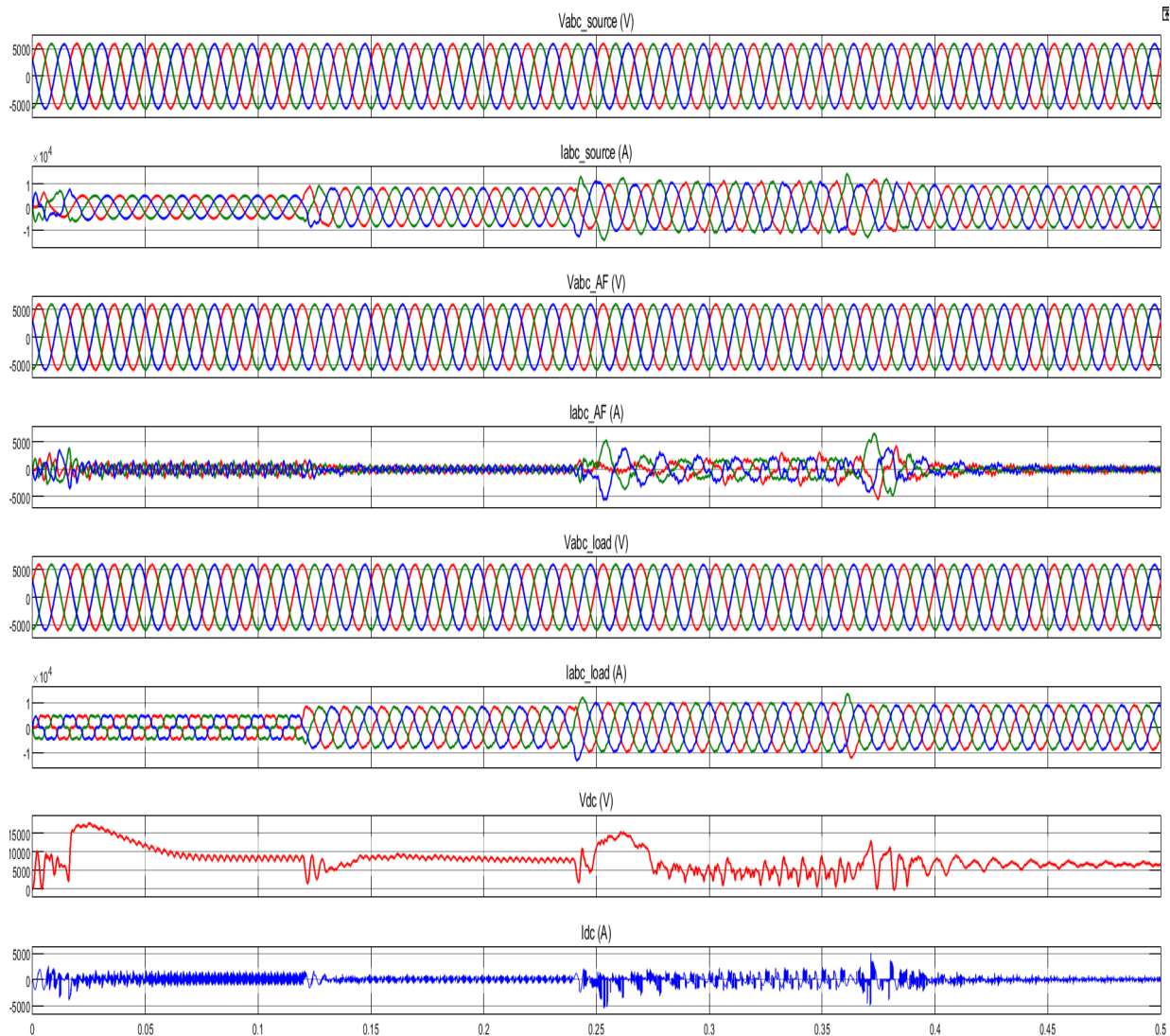

**Fig. 6.** Simulation Results of SAF with PI-SPWM and R, RL and RLE Loads

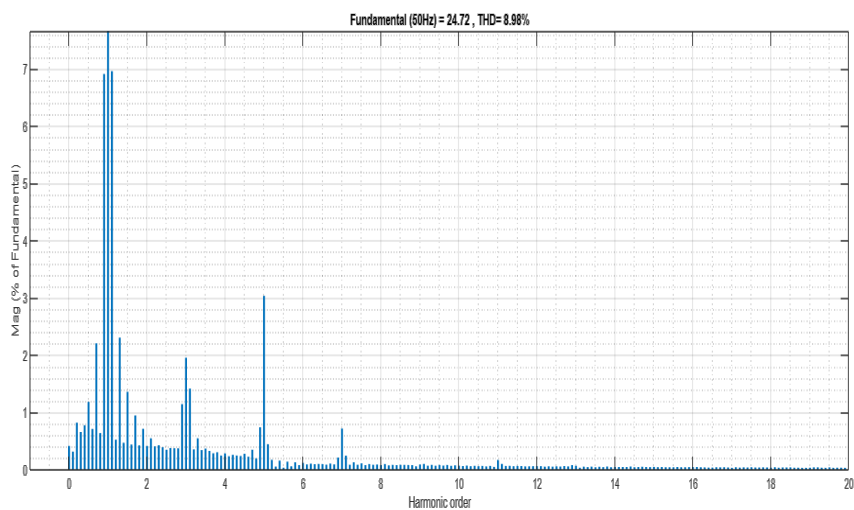

**Fig. 7.** THD of SAF with PI-SPWM and R, RL and RLE Load

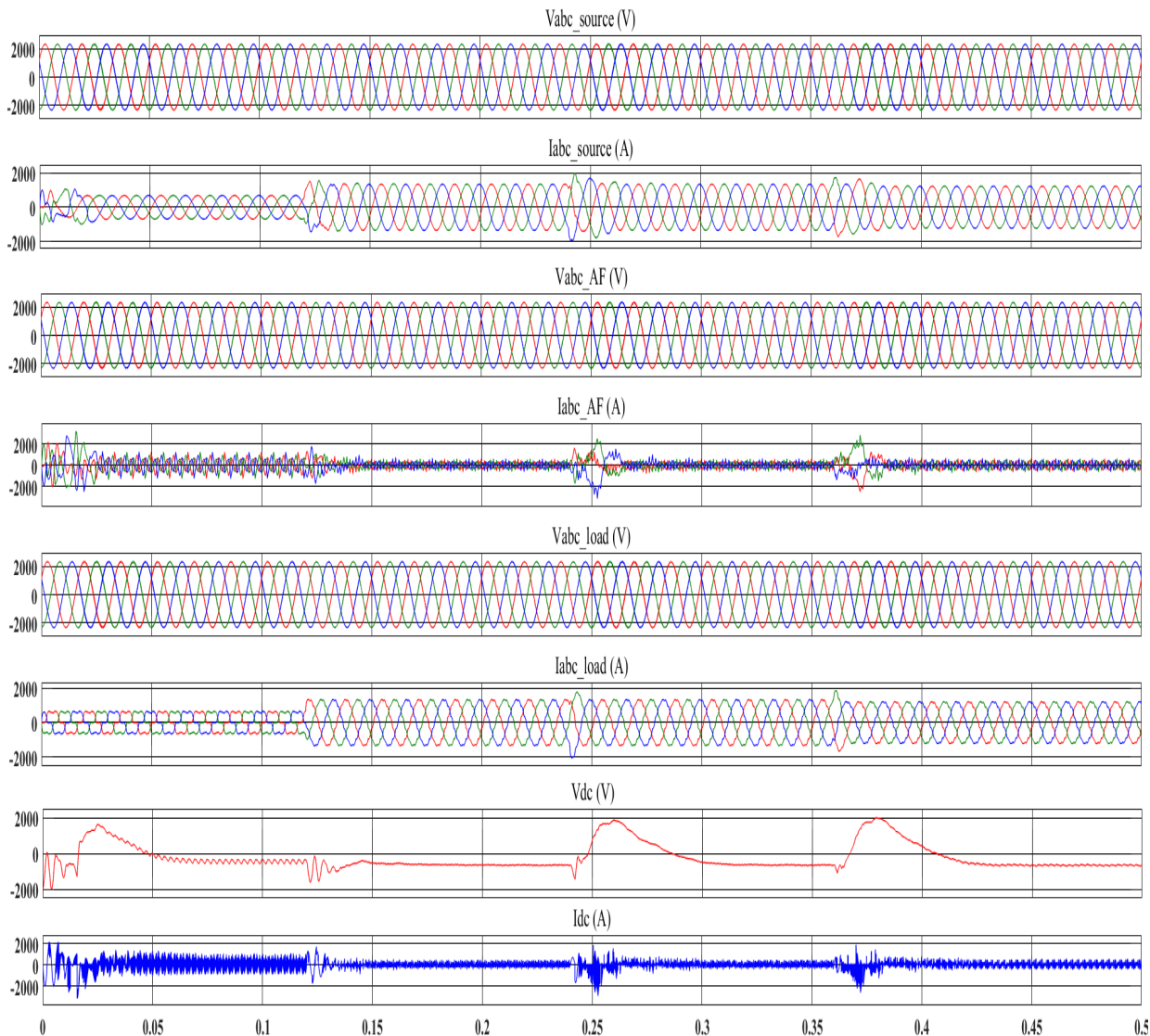



**Fig. 8.** Simulation Results of SAF with PI-SVPWM and R, RL and RLE Loads



**Fig. 9.** THD of SAF with PI-SVPWM and R, RL and RLE Loads



**Fig. 10.** Simulation Results of SAF with PI-SHE PWM and R, RL and RLE Loads

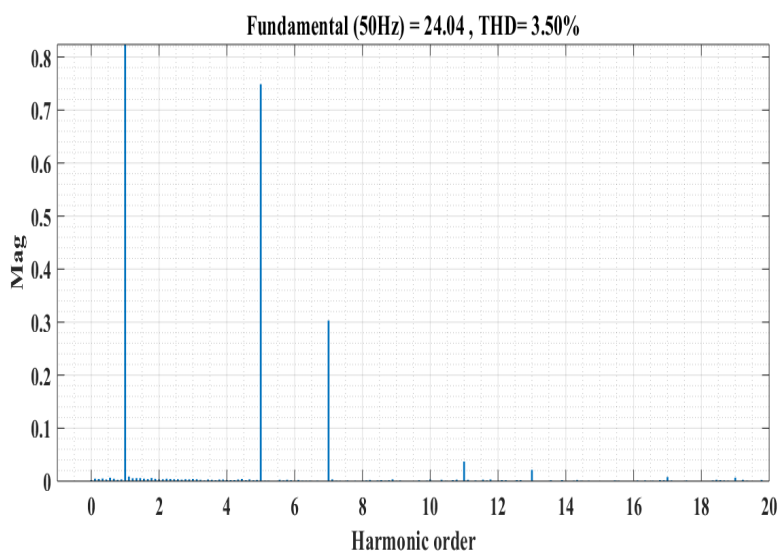

**Fig. 11.** THD of SAF with PI-SHE PWM and R, RL and RLE Loads

**Table.1.** Comparison of Control Schemes

Control	1 <sup>st</sup>	3 <sup>rd</sup>	5 <sup>th</sup>	7 <sup>th</sup>	9 <sup>th</sup>	11 <sup>th</sup>	13 <sup>th</sup>	15 <sup>th</sup>	17 <sup>th</sup>	%THD
[26]	24.72	3.000	2.020	1.270	0.112	0.02	0.010	0.010	0.012	7.38
[27]	22.62	2.72	1.020	0.270	0.12	0.02	0.010	0.011	0.012	6.25
[28]	21.57	2.9000	2.020	1.270	0.21	0.02	0.010	0.010	0.010	7.56
[29]	23.28	2.72	2.020	0.270	0.12	0.02	0.010	0.011	0.012	6.29
[30]	24.61	2.020	1.020	0.270	0.112	0.02	0.011	0.010	0.012	5.92
PI-PWM	25.00	0.031	2.649	1.179	0.012	0.935	0.542	0.008	0.468	31.23
PI-SPWM	23.82	3.000	3.020	1.270	0.172	0.132	0.010	0.010	0.012	9.73
PI-SVPWM	25.72	2.020	3.071	0.980	0.280	0.362	0.162	0.012	0.012	8.98
PI-SHE PWM	24.04	0.001	0.780	0.30	0.001	0.05	0.02	0.001	0	3.50

The comparison results of PWM schemes such as PWM, SPW, SVPWM and SHEPWM along with PI controller is presented in Table 1. The comparison of different PWM schemes such as PWM, SPW, SVPWM and SHEPWM along with PI controller with existing techniques is presented in Table 1. The THD of [26] is 7.38% is more effective than the PI-SPWM control of THD 9.73%. The PI-SVPWM control scheme have THD of 8.98% whereas the [29] have 6.29%. The proposed PI-SHE PWM have less THD of 3.50% compared to existing PWM techniques. Therefore, the SHE-PWM provides the control over the SAF and maintains the load current waveform closer to sinusoidal and THD level in the current waveform is also less as per the IEEE 519 standards.

**5. Conclusions**

A three-phase, three-wire Shunt Active Filter (SAF) based controller has been designed to compensate current harmonics caused by the nonlinear load. The major concern is on the THD reduction in power line using SAF. Hence PWM control schemes such as SPWM, SVPWM and SHE-PWM are developed in association with the PI controller. The PI controller is tuned and gains are fixed using internal model controller (IMC) and the focus is given on PWM control schemes. Additionally, various non-linear loads such as rectifier with R, RL, and RLE load are considered to evaluate the performance of the system. Total Harmonic Distortion (THD) measurements of the system's performance under various load conditions and PWM control schemes have been taken. Results from the simulations show that the THD produced by the suggested SHE-PWM is acceptable according to IEEE 519 when compared to the other PWM techniques. In this work, a simulation work is carried out for verification of system performance and future work is implementation of hardware setup to validation of simulation results. The present work can be further extended by considering artificial intelligence based tuning for controller parameters as future scope of the work.

**6. References**

[1] Mahaboob, S., Ajithan, S. K., & Jayaraman, S., "Optimal design of shunt active power filter for power quality enhancement using predator-prey based firefly optimization". *Swarm and Evolutionary Computation*, Vol. 44, no.1, pp.522–533, 2019.

[2] Basha, S. G., Mani, V., & Mopidevi, S., "Single-phase thirteen-level dual-boost inverter based shunt active power filter control using resonant and fuzzy logic controllers. *CSEE Journal of Power and Energy Systems*, Vol.8, no.3, 2022.

[3] Sarayu Vunnam, M. VanithaSri, A. RamaKoteswaraRao, "Performance analysis of mono crystalline, poly crystalline and thin film material based 6 × 6 T-C-T PV array under different partial shading situations", *Optik*, Vol. 248, p.168055, 2021.

[4] G. S. Rao, B. S. Goud and C. R. Reddy, "Power Quality Improvement using ASO Technique", 9<sup>th</sup> International Conference on Smart Grid (icSmartGrid), 2021, pp. 238-242.

[5] A. M. Colak and K. Kayisli, "Reducing Voltage and Frequency Fluctuations in Power Systems using Smart Power Electronics Technologies: A Review", 9<sup>th</sup> International Conference on Smart Grid (icSmartGrid), 2021, pp. 197-200.

[6] K. Rajani and T. Ramesh., "Maximum power enhancement under partial shadings using a modified Sudoku reconfiguration", *CSEE Journal of Power and Energy Systems*, Vol.7, no.6, pp.1187-1201, 2021.

[7] Ranga Rao Ch, Balamurugan R., RamaKoteswaraRao Alla, "Simulation and Stability Analysis of Three-Phase Shunt Active Filter Based on Internal Model Controller (IMC)", *Journal of Engineering Science and Technology Review*, vol. 14, no.6, pp.154-161, 2021.

[8] Wang, Y., Yin, K., Liu, H., and Yuan, Y., "A Novel Integrated Method for Harmonic Suppression and Reactive Power Compensation in Distribution Network". *Symmetry*, Vol.14, no.7, pp.1347, 2022.

[9] R. Kannan, B. Krishnan, K. Porkumaran, S. Prabakar, I. Elamvazuthi and K. Srinivasan, "Power Quality Improvement Using UPQC for Grid Interconnected Renewable Energy Sources", 8<sup>th</sup> International Conference on Intelligent and Advanced Systems (ICIAS), 2021, pp. 1-6.

[10] RamaKoteswara Rao A., Lekyasri N., Rajani K., "PID Control Design for Second Order Systems",

- International Journal of Engineering and Manufacturing (IJEM), Vol.9, No.4, pp.45-56, July 2019.
- [11] A. Masuda and H. Goto, "Control Strategy for Power Smoothing Converter with Energy Storage for Maximum Power Controlled Wave Energy Converter", 10<sup>th</sup> International Conference on Renewable Energy Research and Application (ICRERA), 2021, pp. 235-238.
- [12] Venkata Mahesh, P., Meyyappan, S., and RamaKoteswaraRao, A., "Multivariate Linear Regression MPPT Algorithm for Solar PV Systems with Boost Converter", The ECTI Transactions on Electrical Engineering, Electronics, and Communications, Vol. 20, no.2, pp. 269-281, 2022.
- [13] Hassan Raji Mhel, Amina Mahmoud Shakir "Total Harmonic Distortion Reduction of 9-Level Packed E-Cell (PEC9) Inverter", International Journal of Smart Grid - ijSmartGrid, Vol.6, no.1, pp.13-22, 2022.
- [14] T. Ramesh, K. Rajani and A. K. Panda. "A novel triple-tied-cross-linked PV array configuration with reduced number of cross-ties to extract maximum power under partial shading conditions", CSEE Journal of Power and Energy Systems, 7(3), 567-581, 2021.
- [15] Habib Benbouhenni, "Utilization of an ANFIS-STSM Algorithm to Minimize Total Harmonic Distortion", International Journal of Smart Grid - ijSmartGrid, Vol. 4, no.2, pp. 56-67, 2020.
- [16] Ravindranath Tagore, Y., Rajani, K. and Anuradha, K., "Dynamic analysis of solar powered two-stage dc-dc converter with MPPT and voltage regulation", Int. J. Dynam. Control. pp. 1-15, 2022.
- [17] Dasari, M. S., and Mani, V., "Simulation and analysis of three-phase parallel inverter using multicarrier PWM control schemes". SN Applied Sciences, Vol.2, no.5, pp.1-10, 2020.
- [18] Kundu, S., Burman, A. D., Giri, S. K., Mukherjee, S., and Banerjee, S."Comparative study between different optimisation techniques for finding precise switching angle for SHE-PWM of three-phase seven-level cascaded H-bridge inverter". IET Power Electronics, Vol.11, no.3, pp. 600-609, 2018.
- [19] Venkata Mahesh, P., Meyyappan, S., RamaKoteswara Rao A., "Maximum Power Point Tracking with Regression Machine Learning Algorithms for Solar PV Systems", International Journal of Renewable Energy Research (IJRER), Vol. 12, no.3, pp. 1327-1338, September 2022.
- [20] Prajna Paramita Dash, Mehrdad Kazerani, "Harmonic Elimination in a Multilevel Current-Source Inverter-based grid-connected Photovoltaic System", IECON 2012 - 38<sup>th</sup> Annual Conference on IEEE Industrial Electronics Society, Vol. 25, pp.1001-1006, 2012.
- [21] RamaKoteswaraRao A., Lather J.S., Pahuja G.L., "Comparison of PI controller performance for first order systems with time delay", Journal of Engineering Science and Technology, vol.12, no.4, pp.1081-1091, 2017.
- [22] Paulo F. Ribeiro, "Common Misapplications of the IEEE 519 Harmonic Standard: Voltage or Current Limits", Power and Energy Society General Meeting - Conversion and Delivery of Electrical Energy in the 21st Century, IEEE, 20-24 July 2008, pp.1-3.
- [23] Diego E. Soto-Sanchez and Tim C. Green, "Voltage Balance and Control in a Multi-Level Unified Power Flow Controller", IEEE Transactions on power delivery, Vol. 16, no. 4, pp.732-738, 2001.
- [24] F. Z. Peng, "A generalized multilevel inverter topology with self voltage balancing," IEEE Trans. Ind. Applicat., Vol. 37, pp. 611-618, 2021.
- [25] Venkatesan, M., Adhavan, B., Suresh, K., Balachander, K., and Prabakar, M. L. C., "Research on FPGA controlled three phase PV inverter using multi carrier PWM control schemes". Microprocessors and Microsystems, Vol.76, Art.no.103089, 2020.
- [26] S. G. Basha, V. Mani and S. Mopidevi, "Single-phase Thirteen-level Dual-boost Inverter Based Shunt Active Power Filter Control Using Resonant and Fuzzy Logic Controllers", CSEE Journal of Power and Energy Systems, Vol. 8, no. 3, pp. 849-863, 2022.
- [27] B. N. Rao, Y. Suresh, A. K. Panda, B. S. Naik and V. Jammala, "Development of cascaded multilevel inverter based active power filter with reduced transformers", CPSS Transactions on Power Electronics and Applications, vol. 5, no. 2, pp. 147-157, 2020.
- [28] G. Pandove and M. Singh, "Robust Repetitive Control Design for a Three-Phase Four Wire Shunt Active Power Filter", IEEE Transactions on Industrial Informatics, vol. 15, no. 5, pp. 2810-2818, 2019.
- [29] Y. Li, Q. Zhou, S. Mu, T. Zhang, H. Li and J. Wang, "A Sliding Mode SVPWM Method for a HTS Shunt Active Power Filter", IEEE Transactions on Applied Superconductivity, vol. 31, no. 8, pp. 1-2, , Art no. 5000902, 2021.
- [30] W. Ding, L. Ming, C. Yin, P. Chiang Loh, B. Duan and C. Zhang, "An Integrated Common-Mode Fast-Balancing Mechanism for Three-Phase Three-Level Converter with LCL Filter", IEEE Transactions on Power Electronics, Vol. 36, no. 11, pp. 12694-12709, 2021.