

Non-Catalytic Slow Pyrolysis of *Spirulina Platensis* Residue for Production of Liquid Biofuel

Siti Jamilatun^{***}, Arief Budiman^{****†}, Budhijanto^{*}, Rochmadi^{*}

^{*}Department of Chemical Engineering, Faculty of Engineering, Gadjah Mada University, Jalan Grafika 2, Yogyakarta 55284, Indonesia

^{**}Department of Chemical Engineering, Faculty of Industrial Technology, Ahmad Dahlan University, Jalan Kapas 9, Yogyakarta 55166, Indonesia

^{***}Center for Energy Studies, Gadjah Mada University, Sekip K1A, Yogyakarta, Indonesia

(siti.jamilatun@che.uad.ac.id, abudiman@ugm.ac.id, budhijanto@ugm.ac.id, rochmadi@ugm.ac.id)

[†]Corresponding Author; Arief Budiman, Department of Chemical Engineering, Faculty of Engineering, Gadjah Mada University, Tel: +62 274 902171,
Fax: +62 274 902170, abudiman@ugm.ac.id

Received: 11.04.2017 Accepted: 25.07.2017

Abstract- The concerns in oil reserves depletion and environmental problems demand renewable energy sources, including biofuel, to be continuously developed. The residue from *Spirulina platensis* extraction is a source of biomass which can be pyrolysed to obtain liquid fuel. This paper examines the characteristics of pyrolysis with Thermogravimetric Analyzer (TGA) and the slow pyrolysis of *Spirulina platensis* residue (SPR) with a fixed-bed reactor without catalysts. The result of TGA analysis with a heating range from 30 to 1000°C indicated that 20°C/min was the best heating rate while the minimum temperature for thermal decomposition was 302.06°C. Pyrolysis experiments in a fixed-bed reactor were performed using 50 grams of SPR as feed, with a pyrolysis temperature between 400-650°C. The maximum bio-oil yield of 25% was produced at a temperature of 550°C, where the aromatic components and phenol increased. The higher heating value (HHV) of bio-oil was quite high (25.70 MJ/kg). On the other hand, the gas products which were dominated by H₂, CO, and CH₄, can be used as syngas fuel meanwhile the bio char product that had high C content (50.31%) and ash content (11.80%) exhibits a great potential as an adsorbent and catalyst.

Keywords *Spirulina platensis* residue, non-catalytic slow pyrolysis, fixed-bed, biofuel.

1. Introduction

The world's energy consumption from non-renewable sources (coal, oil, and gas) is experiencing a sudden increase as the growth of global population is exponentially proliferating [1-4]. Consequently, in order to meet the needs of the global consumption, a fuel to drive a wide variety of industrial and transport sectors is profusely required. According to Energy Information Administration, the global demand for natural resources showed an increasing trend from year to year, at a point where the need for oil will increase by 35% in 2025. On the other hand, the need for energy from fossil fuels is estimated at around 78% of energy use by 2040 [5].

The dominance of fossil energy use of non-renewable resources has led to the depletion of oil reserves and a striking increase in CO₂ emissions. These conditions lead to global warming, which in turn poses a threat to the global climate change [2;6;7]. As a consequence, the energy problems demand development of energy sources derived from renewable sources that are more environmentally friendly and sustainable. The energy consumption from renewable sources (wind, sun, waves and biomass) has increased to an average of 2.6% per year worldwide between the years 2012 to 2040 [5;8]. These enhancements provide an opportunity to develop the energy sources of biomass into fuels (biofuels) as an attractive choice and fit for effective use.

As a product of biomass processing, biofuel can be produced in the form of bio-oil, bioethanol, biodiesel, bio-syngas, bio hydrogen and biogas. Until now, the biofuel-based energy source has undergone several generations of development [9;10]. The first generation (G1), derived from grains and sugar and food oil, is utilized to produce ethanol and biodiesel respectively. Unfortunately, the biomass sources of G1 are in conflict with the needs of food and henceforth its utilization as a raw material to produce biofuel would irrefutably destabilize food reserves. The second generation (G2) includes alcohol and green diesel derived from lignocellulose and green diesel derived from non-edible oil. While the sources of biomass from G2 do not necessarily interfere with food safety, their plantation can reduce soil fertility. Until now, the disadvantages of G1 and G2 biofuel as an energy source can be resolved by the third generation (G3), which is the biomass of microalgae, that can be converted into biofuels and chemicals [11;12;13].

As a source of G3 biomass, microalgae offers many promising advantages due to its notably high growth rate, high result of cultivation of each area, and high efficiency in capturing CO₂. Moreover, microalgae do not compromise the security of food supply stability and can be converted into a product using various mechanisms [14–16]. Several pathways to converting microalgae are biochemical conversion (including photo biological hydrogen production, fermentation, anaerobic digestion), thermochemical conversion (gasification, pyrolysis, liquefaction), chemical reaction (trans-esterification) and direct combustion (power generation). Furthermore, to obtain liquid biofuels (bio-oil), microalgae can be converted through thermochemical conversion (pyrolysis) [17;18;19].

An energy-efficient algae-refinery with thermochemical conversion as seen in Fig. 1 is proposed. The conversion of microalgae starts from cultivation, harvesting, and extraction (producing algae and algae oil residues), during which the algae oil undergoes transesterification to produce biodiesel while algae residue is fed into pyrolysis unit (temperature of 300-600°C) to produce bio-oil. Subsequent gasification (temperature of 600-900°C) after pyrolysis will produce syngas and CO₂ [20]. These products of the gasification (900°C) can be used as a heat source in the pyrolysis to a temperature of 600°C, then the hot gases produced from pyrolysis (syngas and CO₂) with a temperature of 600°C is partly used for the transesterification at 65°C [21]. The residual heat that comes out of the transesterification with a temperature of 65°C is later used for heating in the extraction step (45°C) and for drying at harvesting step (30°C) [22]. In addition, the CO₂ content in the residual heat stream that comes out of harvesting and extraction in the form of syngas is required for cultivation (see Fig. 1).

Extraction is one of the important processes of algae-refinery [23; 24]. There are two types of extraction; one method uses a green solvent from the extraction plant (FAME, terpene) while another method applies the intensification of the processing method such as wet algae biomass extraction, microwave-assisted extraction, ultrasound-assisted extraction, surfactant-assisted extraction, enzyme-assisted extraction, and in situ transesterification

[25;26]. For both methods, microalgae extraction will produce algae oil as the primary product along with microalgae residue [27].

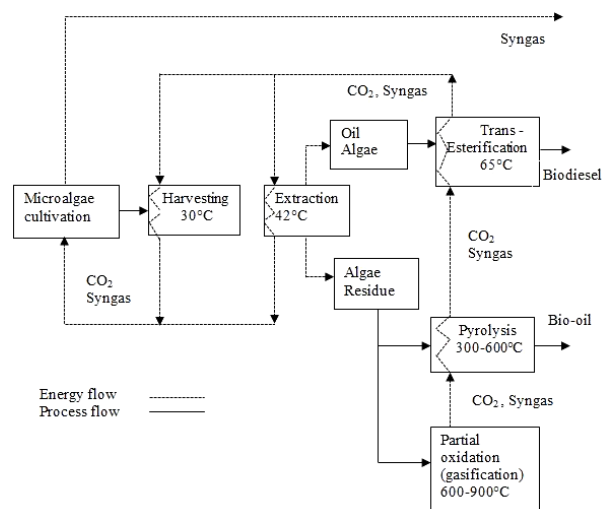

Fig. 1. Energy-efficient algae refinery.

Due to its high carbohydrate and protein content, microalgae residue can be pyrolysed (at 300-600°C) to produce bio-oil, gas, and bio char [28;29]. Generally, pyrolysis can be classified into fast pyrolysis and slow pyrolysis. The selection of types of pyrolysis depends on the desired products which can be adjusted by controlling the heating rate, residence time, and the type of reactor [30;31]. As the utilization of microalgae as energy source is generating considerable interest, there have been numerous studies discussing pyrolysis of microalgae without catalysts by fast pyrolysis [32;33], by slow pyrolysis [34], and using microalgae residue as raw material (35–37). However, the characteristics of bio-oil produced from pyrolysis of solid waste generated from *Spirulina platensis* extraction using a fixed-bed reactor with a slow heating rate (10-50°C/s) without catalyst have not been investigated.

This study examines the influence of temperature rise of the slow pyrolysis of SPR with a non-catalytic fixed-bed reactor in the product yield (bio-oil, gas, and bio char). The content of each constituent in the product yield is analyzed and later discussed to understand the correlating phenomenon that occurs between pyrolysis temperature changes and components of the product yield. Moreover, this paper also studied the effect of temperature rise with a wide range of heating rate on the characteristics of pyrolysis performed with Thermogravimetric Analyzer (TGA).

2. Materials and Methods

2.1. Materials

Spirulina platensis was extracted to produce algae oil and its residue. The residue obtained was then separated and used as raw material for pyrolysis. Furthermore, fresh *Spirulina platensis* and its residue (SPR) were characterized by ultimate analysis, proximate analysis, and higher heating value (HHV) analysis. These tests were conducted at the Laboratory of Chemistry, Biochemistry of Food and

2.2. Microalgae Residue Pyrolysis Characterization

Characterization of SPR pyrolysis was done using TGA to determine the weight change of SPR during the pyrolysis temperature change and to determine the thermal decomposition temperature at each heating rate. Pyrolysis was performed at a temperature of 30 to 1000°C with a heating rate of 10, 20, 30 and 50°C/min. At 120 and 600°C, the temperature was maintained for 10 minutes to ensure complete evaporation and pyrolysis. A similar method was done by Cylen *et al.* (2014) [38], when the heating temperature reached 110°C, the temperature was kept steady for 20 min. to ensure that all water vapour was released from the material. This resulted in a constant weight in a specific period of time, as indicated by the horizontal line on the TG curve [39]. Another similar method was performed by Daniyanto *et al.* (2016), when the temperature reached 500°C, the temperature was maintained for 15 minutes, ensuring a complete pyrolysis [40].

2.3. Experiment with Non-catalytic Fixed-bed Pyrolyzer

Non-catalytic slow pyrolysis experiment was performed in a cylindrical fixed-bed reactor with an inside diameter of 40 mm, outer diameter of 44 mm, and length of 600 mm. This reactor was equipped with a coil-shaped electric heater wrapped around the outer surface of the cylinder. The temperature was controlled using a thermocouple. Reactor was also equipped with a condenser and condensate container. Non-condensable gasses were collected and analyzed to calculate the composition of each constituent. Schematic drawing of the pyrolysis unit is shown in Fig. 2.

Pyrolysis process was performed by feeding 50 grams of SPR into the reactor, followed by equipping the thermocouple and covering the reactor properly. Condenser, bio-oil & gas cooler and container were strung together as illustrated in Fig. 2. The reactor was heated by an electric heater with a constant heating rate of 10°C/min until the desired pyrolysis temperature was achieved (400, 450, 500, 550, 600, 650°C). Then, the reactor temperature was kept constant for 1 hour. The resulting pyrolysis gas was then condensed and collected in a bottle. The resulting condensate will form two layers: the top layer (bio-oil) and lower layer (water phase). Furthermore, the liquid on top layer (bio-oil) was measured in volume. Bio char could be taken and weighed after pyrolysis was complete, at which time the reactor has been cooled. Non-condensable gas was stored in the gas storage bottle.

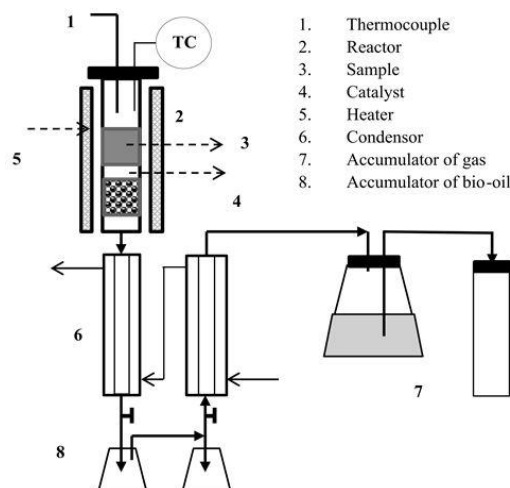

Fig. 2. Schematic diagram of fixed-bed tubular reactor.

2.4. Product Analysis: Bio-oil, Gas, and Char

The experiment was performed three times for each pyrolytic temperature, of which the yields were average, and three products (liquid, char and gas) were obtained. The liquid product is a mixture of the oil phase (bio-oil) and the water phase, both of which can be separated by gravity into the upper oil phase and the bottom water phase. Each weight of bio-oil and water phase was weighed and recorded. Subsequently, the char obtained at the end of the pyrolysis was weighed and recorded. The weight of gas product can be determined by calculation, i.e. the initial weight of SPR minus the weight of the liquid and the char. From pyrolysis of SPR, the yield percentage of liquid product (Y_{liq}), yield of water phase (Y_{wtr}), yield bio-oil (Y_{bo}), yield char (Y_{char}) and yield gas (Y_{gas}) were calculated by using Eq. (1) – (5) [34].

$$Y_{liq} = (W_{liq}/W_{SPR}) \times 100\% \quad (1)$$

$$Y_{aqz} = (W_{wtr}/W_{SPR}) \times 100\% \quad (2)$$

$$Y_{bo} = (W_{bo}/W_{SPR}) \times 100\% = Y_{liq} - Y_{aqz} \quad (3)$$

$$Y_{ch} = (W_{ch}/W_{SPR}) \times 100\% \quad (4)$$

$$Y_{gas} = 1 - (Y_{liq} + Y_{ch}) \quad (5)$$

Where Y_{liq} is the yield of liquid product; W_{liq} is the weight of liquid product; W_{SPR} is SPR weight; Y_{aqz} is the yield of water; W_{wtr} is the weight of water phase; Y_{bo} is the yield of bio-oil; W_{bo} is the weight of bio-oil; Y_{ch} is the yield of biochar; W_{char} is char weight and Y_{gas} is the yield of gas.

Constituents of bio-oil produced from pyrolysis were tested by GC-MS, meanwhile, the gas component product was analyzed with gas chromatography-thermal conductivity detector (TCD). Proximate and ultimate analysis of both bio-oil and bio char were done at Laboratory of Food and Nutrition, International University Centre (IUC), Gadjah Mada University, Yogyakarta, Indonesia.

3. Results and Discussion

3.1. *Spirulina platensis* and SPR Analysis

The composition, proximate and ultimate analysis results of *Spirulina platensis* and SPR are presented in Table 1. The small lipid content of SPR (0.09%) indicates that *Spirulina platensis* extraction can take almost any algae oil. On the other hand, the high content of carbohydrate (38.51%), protein (49.60%) and volatile (68.31%) of SPR will affect the yield of the resulting liquid. In addition, a low molar ratio O/C value implies that only a small amount of polar compounds are present in *Spirulina platensis* and SPR. However, a high value of H/C indicates a considerable amount of aliphatic hydrocarbon compounds. Both O/C and H/C values affect the higher heating value (HHV) as the H/C value increases and O/C value decreases, the HHV will increase accordingly. The influence of O/C and H/C values is reflected on HHV of SPR (18.21 MJ/kg) which is notably lower than *Spirulina platensis* (20.09 MJ/kg). Meanwhile, inorganic materials such as Ca and K content experience a significant increase after extraction with only Mg that decreases, mainly due to the material stripping during extraction and leaching.

3.2 Characteristics of microalgae pyrolysis residue

The weight loss profile on pyrolysis (TGA) and the rate of weight loss per time (DTG) with a variation of heating rate (10, 20, 30 and 50°C/min) can be seen in Fig. 3 and 4. The results indicate that the TGA-DTG profile has a similar tendency for heating at a different rate. The results of TGA to a temperature of 30 to 1000°C are shown in Fig. 3.

As can be seen in Fig. 3, pyrolysis consisted of three stages, where the division of stage is based on the magnitude of weight change for every rise in temperature. In Stage I, various heating rate occurs at a temperature range of 30-220°C, water dehydration occurred at an average of 11.5%. In Stage II (temperature range of 220-600°C), there was a weight loss of SPR with an average of 59.25% during the pyrolysis process. Moreover, at this period, various compounds such as benzene, toluene, phenol alkenes, alkanes and their derivatives, carboxylic acids, esters, aldehydes, ketones, n-heterocycles, amines, amides, naphthalene, indene and its derivatives were also formed. Stage III (temperature range of 600-1000°C) is called gasification, where the occurring weight loss was relatively insignificant. The most optimum weight loss occurred in Stage II with a heating rate of 20°C/min, amounted to 72%.

DTG thermal decomposition can be observed in Fig. 4. The values of minimum or maximum peak in the DTG curves illustrate the required thermochemical activation energy for the reaction. The lowest peak occurred at the heating rate of 20°C/min, whereas the thermal decomposition temperature of the heating rate of 10, 20, 30 and 40°C/min was 303.1, 302.1, 315.5 and 333°C. Therefore, the lowest thermal decomposition occurred at the heating rate of 20°C/min. This might imply that at 20°C/min, faster decomposition reaction was completed with smallest activation energy.

Table 1. Main characteristic of *Spirulina platensis* (SP) and *Spirulina platensis* residue (SPR)

Component	SP	SPR
Composition analysis (%)		
Lipid	0.25	0.09
Carbohydrate	46.13	38.51
Protein	44.72	49.60
Proximate analysis (%)		
Moisture	11.83	9.99
Ash	8.63	8.93
Volatiles	67.03	68.31
Fixed carbon	12.51	12.77
Ultimate analysis (%)		
Sulfur	0.49	0.55
Carbon	41.91	41.36
Hydrogen	6.82	6.60
Nitrogen	8.89	7.17
Oxygen	33.04	35.33
H/C, molar ratio	1.95	1.91
O/C, molar ratio	0.59	0.64
Higher heating value (MJ/kg)	20.09	18.21
Ca	0.91	1.25
Mg	2.70	0.48
K	0.17	0.51

The comparison between the thermal decomposition of the SPR at the heating rate of 20°C/min with other biomasses was provided in Table 2. It can be seen that the SPR has the lowest decomposition temperature (302.1°C) to achieve maximum yield (0.05/min), compared with coconut shell, corn corb, palm shell and spirulina platensis. This indicates that the SPR is easiest to react, with the least volatile material so that the yield of bio-oil is consequently less.

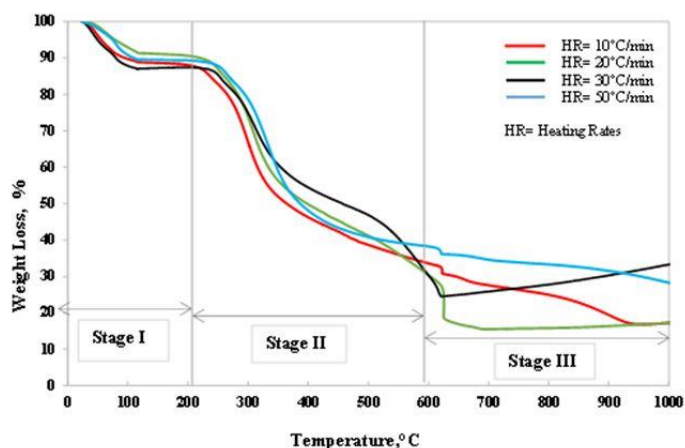

Fig. 3. Thermogravimetric behavior of SPR at different heating rates versus mass loss (%).

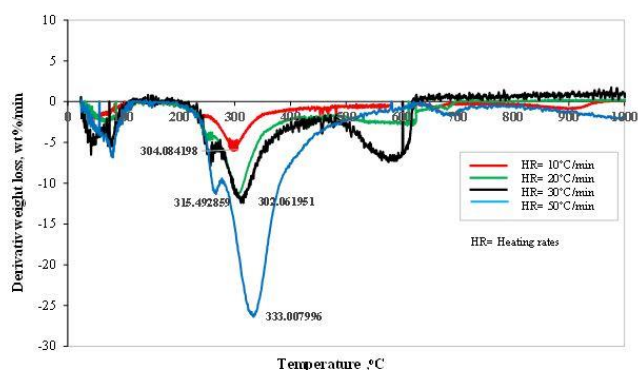

Fig. 4. DTG plots of SPR Pyrolysis at various heating rate.

Table 2. Comparison of SPR decomposition with other biomass sources [14]

Biomass	Temperature at maximum yield of decomposition (T_{max} , °C)	Maximum yield of decomposition (min^{-1})	Remainin g solid residue at 1000°C (%)
Coconut shell	355	0.1820	22.07
Corn cob	346	0.2790	10.00
Palm shell	377	0.1790	20.80
<i>Spirulina sp.</i>	324	0.0704	25.96
SPR ^(a)	302.1	0.0500	29.00

a: this experiment

3.3 Non-catalytic Fixed-bed Pyrolysis

The pyrolysis was carried out at a temperature of 400-650°C with a heating rate of 10°C/min. The resulting product consisted of liquid phase (bio-oil and water phase), gas and bio char, where the yield of each product is presented in Fig. 5. The yield of bio-oil at a temperature of 400°C was the lowest (13 wt.%); it rose sharply to a temperature of 550°C with a maximum yield (25.1 wt.%), and then fell again as the temperature rose. Meanwhile, the gas yield at a temperature of 400 to 550°C was relatively stable (25 wt.%), but experienced a slight rise (to 27.5 wt.%) at a temperature of 650°C. In addition, the yield of bio char at 400-500°C was relatively stable (32.5 wt.%), before subsequently decreased to 30 wt.% at 600°C.

Compared with lignocellulosic pyrolysis (400-650°C), the optimum temperature for SPR slow pyrolysis is lower (400-550°C) [30]. This is because: (i) SPR component consists primarily of carbohydrates, proteins, and lipids that are easier to pyrolyze than lignocellulose (cellulose, hemicellulose, and lignin), (ii) the cell structure of the SPR is softer, (iii) SPR contains more inorganic materials than lignocellulosic which could provide catalytic effect [14].

3.4 Yield of Bio-oil, Gas and Bio Char

3.4.1 Bio-oil from pyrolysis

Fig. 6 shows effect of temperature on hydrocarbon fraction in the bio-oil. From the trend shown in Fig. 6, it can be drawn that the yield and components of bio-oil are influenced by pyrolysis temperature. Bio-oil contains more than 100 components but can be primarily categorized into nine functional groups: aromatic (C_7H_8 , C_7H_9N , C_8H_7N , C_9H_9N), heterocyclic (C_5H_7N , C_6H_9N , $C_8H_{13}N$), phenol (C_6H_6O , C_7H_8O , $C_8H_{10}O$), amine ($C_{10}H_{15}N$, $C_{19}H_{37}NO$), amide ($C_6H_{13}NO$, $C_8H_{11}N$, $C_{16}H_{33}NO$, $C_{16}H_{37}NO$), indole (C_8H_7N , C_9H_9N), alkane ($C_{17}H_{36}$), nitrile ($C_{16}H_{31}N$) and few acids. At 400°C, bio-oil contains many alkanes (58 wt.%) then at 600°C alkane component will decrease (38 wt.%). While indole, acid, heterocyclic amines, amides, amines and nitrile has a low concentration, other components are relatively stable. The only components that increased as the temperature rose were phenol (7-18 wt.%) and aromatics (8-22 wt.%).

A comparison of the characteristics of bio-oil from SPR, timber and heavy naphtha is listed in Table 3. Similar to kerosene, diesel and heavy naphtha oil, bio-oil has a carbon chain of C5-C19 ranges. Moreover, bio-oil derived from SPR and wood has a fairly high oxygen content, which is 35.63 wt.% and 35-40 wt.%, respectively, while heavy fuel oil only has 1 wt.% of oxygen content. A high water content, high pH value, and high oxygen content promote a decrease in heavy heating value (HHV) and possibly corrosion. However, bio-oil derived from SPR still has higher HHV (27.8-28.0 MJ/kg) than the HHV of wood (16-19 MJ/kg).

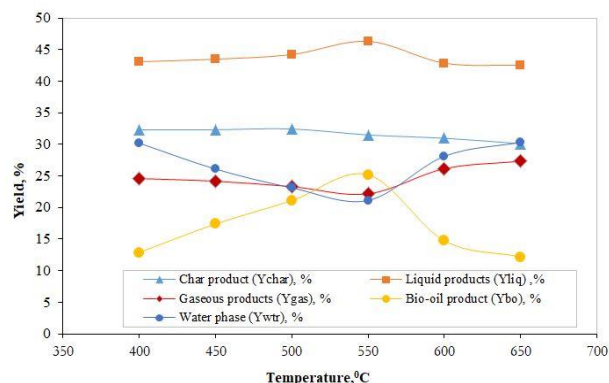

Fig. 5. The effect of temperature on product yield.

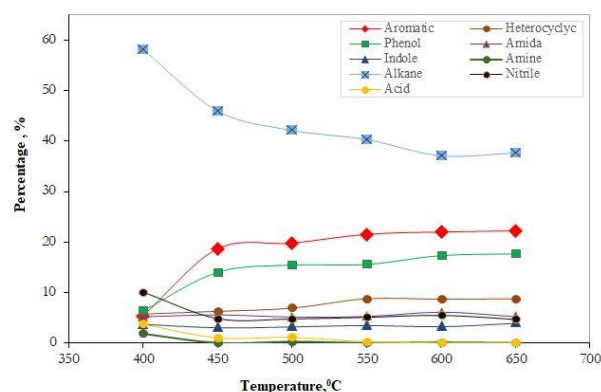

Fig. 6. Composition of hydrocarbon fraction in bio-oil.

The most adverse disadvantage of bio-oil derived from biomass due to the extremely high content of oxygenate compounds can be overcome by the use of catalysts during pyrolysis, which reduces the content of oxygenate compounds. It was found that the bio-oil of crude *Chlorella pyrenoidosa* algae produced by using 20% platinum catalyst on gamma alumina (Pt/ γ -Al₂O₃) had a lower O/C content (0.060) than in non-catalytic process (0.125) [37]. In addition, the high water content and ash can be overcome by physical separation, while the pH content will drop with catalytic cracking and the notably high acid content will be reduced by the presence of carboxylation reaction followed by carbonylation [39].

3.4.2 Gas from pyrolysis

The gas yield produced during pyrolysis at 450-650°C as well as its composition can be seen in Table 4. As expected, the gas composition mainly consisted of H₂, CO, CO₂, and CH₄, with the volume percentage (%) being affected by pyrolysis temperature. The optimum concentration of H₂ (52.99 vol.%), CO (24.49 vol.%) and CH₄ (33.07 vol.%) was obtained at the optimum temperature of 600°C. Furthermore, volatile compounds, polar and non-polar compounds with low molecular weight were formed as a result of dehydration and thermal cracking at high temperatures. Consequently, the yield of liquid (bio-oil and water phase) rose with the increase in temperature of 400-550°C. Meanwhile, with the pyrolysis temperature of over 550°C, volatile compounds in bio-oil which is condensed at low temperatures split into non-condensable gas, resulting in a decrease in the yield of bio-oil.

Table 3. Comparison between the properties of pyrolysis oil from SPR with wood pyrolysis and heavy fuel oil [11]

Physical property	Heavy fuel oil	Bio-oil from wood	Bio-oil from SPR ^(a)
Element composition (wt.%)			
C	85	54 - 58	46.05
H	11	5.5 - 7.0	8.77
O	1.0	35 - 40	35.63
N	0.3	0 - 0.2	9.47
Ash	0.1	0 - 0.2	0.08
HHV (MJ/kg)	40	16 - 19	25.70
Viscosity (at 50°C)	180	40 - 100	40 - 68
Moisture (wt.%)	0.1	15 - 30	35.68
pH	-	2.5	9
Specific gravity	0.94	1.2	1.09

Table 4. Composition of various gaseous products (vol.%) at different temperatures in the pyrolysis process

Temperature, °C	H ₂	CO ₂	CO	CH ₄
450	0.00	0.00	20.81	0.00
500	12.49	8.09	8.67	19.17
550	26.22	17.15	13.76	35.23
600	52.99	6.22	24.29	33.07
650	0.00	0.00	21.29	0.00

3.4.3 Yield of Bio Char

The result of bio char ultimate analysis is presented in Table 5. In regards to carbon (C), hydrogen (H), nitrogen (N) and ash content, C content in bio char from SPR (50.31%) is higher than *Spirulina* sp. (45.26%), but lower than the lignocellulose (67.7%). This indicates that SPR bio char has a potential to be applied as activated carbon for adsorption. The high H content in bio char also implies that many hydrogen atoms are still attached to bio char. In addition, the high ash content in SPR bio char indicates high inorganic material (K, Ca, Mg, Si, etc.) content, which makes bio char an attractive fit to be used as a catalyst.

Table 5. Ultimate analysis of SPR bio char in comparison with *Spirulina* sp. Bio char and Oak bio char [14]

Component	SPR bio char, % ^(a)	<i>Spirulina</i> sp. Bio char, %	Oak bio char, %
C	50.31	45.26	67.70
H	8.81	1.24	2.40
N	5.74	2.57	0.40
Ash	11.80	47.82	14.90

4. Conclusion

The residue from *Spirulina platensis* extraction exhibits a promising potential as source of biomass for pyrolysis. With a relatively high volatile content (68.31 wt.%) and carbohydrates content (38.51 wt.%), pyrolysis of SPR produced a maximum bio-oil yield (25%) at 550°C. Even though the HHV of bio-oil from SPR is lower (27.8-28.0 MJ/kg) than heavy fuel oil (40 MJ/kg), it is still higher than bio-oil from wood (17-19 MJ/kg) in addition to also being a renewable energy source that is safe for the environment. The heating rate of pyrolysis required for the activation energy was the lowest at 20°C/min. According to GC-MS result, the temperature rise of bio-oil (400-650°C) caused the aromatic components and phenol to rise (8-23%) as opposed to aliphatic content which decreased and the content of other components which were relatively stable. The product gas at 600°C, dominated by H₂ (52.99 vol.%), CO (24.49 vol.%) and CH₄ (33.07 vol.%), exhibits enormous potential to be used as syngas. On the other hand, the bio char product, with a high C content (50.31%) and ash content (11.80%) creates an alternative application as an adsorbent and catalyst.

Acknowledgements

This work was supported by Directorate General of Higher Education, Ministry of Research Technology and Higher Education, Republic of Indonesia for supporting and donation in the scheme of "International Research Collaboration and Scientific Publication" under supervision of Research Institution and Community Service, Gadjah Mada University, Yogyakarta, Indonesia. The authors also thank Muhamad Hartono for his help during the manuscript preparation.

References

- [1] Sunarno, Rochmadi, P. Mulyono, and A. Budiman, "Catalytic cracking of the top phase fraction of bi-oil into upgraded liquid product", AIP Conference Proceedings, 1737 (2016), 060008.
- [2] A. Marcilla, J.C.L. Catalá, García-Quesada, F-J. Valdés, and M.R. Hernández, "A review of the biochemical conversion of microalgae", *Renew Sust Energ Rev*, vol. 27, pp. 11–19, 2013.
- [3] D.R. Wicakso, Sutijan, Rochmadi, and A. Budiman, "Catalytic decomposition of tar derived from wood waste pyrolysis low grade iron ore as catalyst", AIP Conference Proceedings 1737 (2016), 060009.
- [4] Z. Mufrodi, Rochmadi, Sutijan, and A. Budiman, "Synthesis acetylation of glycerol using batch reactor and continuous reactive distillation column", *Eng. J.*, vol. 18(2), pp. 30-41, 2014.
- [5] Energy Information Administration (EIA), International Energy Outlook 2016. <http://www.eia.doe.gov/oiaf/ieo/index.html> (Accessed Date: 21 July 2016).
- [6] S. Mohapatra and K. Gadgil, "Biomass: The Ultimate Source of Bio Energy", *Int. J. Renew. Energy Res*, vol. 3(1), pp. 20-23, 2013.
- [7] J.P. Maity, J. Bundschuh, C-Y. Chen, and P. Bhattacharya, "Microalgae for third generation biofuel production, mitigation of greenhouse gas emissions and wastewater treatment: Present and future perspectives, A mini review", *Energy*, pp. 1-10, 2014.
- [8] F. Wieland, H. Gueldner and O. R. Hild, "Renewable energy and lightings - logically or artificially?," 2012 International Conference on Renewable Energy Research and Applications (ICRERA), Nagasaki, 2012, pp. 1-5; doi:10.1109/ICRERA.2012.6477351
- [9] R.D. Kusumaningtyas, S. Purwono, Rochmadi, and A. Budiman, "Graphical exergy analysis of reactive distillation column for biodiesel production", *Int J Exergy*, vol. 1(4), pp. 447-467, 2014.
- [10] M. Oku, T. Sakoda, N. Hayashi and D. Tashima, "Basic characteristics of a heat and electricity combined generation system using biomass fuel," 2014 International Conference on Renewable Energy Research and Application (ICRERA), Milwaukee, WI, 2014, pp. 222-228; doi:10.1109/ICRERA.2014.7016560.
- [11] G. Dragone, B. Fernandes, A. Vicente, and J.A. Teixeira, "Third generation biofuels from microalgae", In: Vilas AM, editor. Current research, technology and education topics in *Appl Microbiol Biot*, Badajoz: Formatex Research Center; 1355-66, 2010.
- [12] S. Zighmi, S. Ladjel, M.B. Goudjil, and S.E. Bencheikh, "Renewable Energy from the Seaweed *Chlorella pyrenoidosa* Cultivated in Developed Systems", *Int. J. Renew. Energy Res*, vol. 7(1), pp. 50-57, 2016.
- [13] M. Aziz, T. Oda and T. Kashiwagi, "Novel power generation from microalgae: Application of different gasification technologies," 2015 International Conference on Renewable Energy Research and Applications (ICRERA), Palermo, 2015, pp. 745-749; doi: 10.1109/ICRERA.2015.7418510
- [14] K. Chaiwong, T. Kiatsiriroat, N. Vorayos, and C. Thararax, "Study of bio-oil and bio-char production from algae by slow pyrolysis", *Biomass Bioenerg.*, vol. 56, pp. 600-606, 2013.
- [15] P. Sii-uam, C. Linthong, S. Powtongsook, K. Kungvansaichol, and P. Pavasant, "Manipulation of biochemical composition of *Chlorella* sp.", *Eng J*, vol. 19(4), pp. 13-24, 2015.
- [16] K.K. Sharma, S. Garg, Y. Li, A. Malekizadeh, and P.M. Schenk, "Critical analysis of current Microalgae dewatering techniques", *Biofuels*, 2014, Retrieved from <http://www.tandfonline.com/doi/abs/10.4155/bfs.13.25#.VN9VCC5L7t0>
- [17] J. Milano, H.C. Ong, H.H. Masjuki, W.T. Chong, M.K. Lam, P.K. Loh, V. ellayan, "Microalgae biofuels as an alternative to fossil fuel for power generation", *Renew. Sust Energ Rev*, vol. 58, pp. 180–197, 2016.
- [18] M. Aziz, T. Oda, T. Mitani, A. Uetsuji and T. Kashiwagi, "Combined hydrogen production and power generation from microalgae," 2015 International Conference on Renewable Energy Research and Applications (ICRERA), Palermo, 2015, pp. 923-927; doi:10.1109/ICRERA.2015.7418544.
- [19] E. K. Çoban, C. Gençoğlu, D. Kirman, O. Pinar, D. Kazan and A. A. Sayar, "Assessment of the effects of medium composition on growth, lipid accumulation and lipid profile of *Chlorella vulgaris* as a biodiesel feedstock," 2015 International Conference on Renewable Energy Research and Applications (ICRERA), Palermo, 2015, pp. 793-796; doi: 10.1109/ICRERA.2015.7418521.
- [20] W.H. Chen, B.J. Lin, M.Y. Huang, and J.S. Chang, "Thermochemical conversion of microalgal biomass into biofuels: review", *Bioresour Technol*, vol. 184, pp. 314-327, 2015.
- [21] C. Prommuak, P. Pavasant, A.T. Quitain, M. Goto, and A. Shotipruk, "Microalgal lipid extraction and evaluation of single-step biodiesel production", *Eng J*, vol. 16(5), pp. 57-166, 2012.
- [22] G. Di Giacomo and L. Taglieri, "Development and Evaluation of a New Advanced Solid Bio-Fuel and Related Production Process", *Int. J. Renew. Energy Res*, vol. 3(2), pp. 255-260.
- [23] G.A. Nafis, P.Y. Mumpuni, Indarto, and A. Budiman, "Combination pulsed electric fields with ethanol solvent for *Nannochloropsis* sp. Extraction," AIP Conference Proceedings, 1699 (2015): 030021.
- [24] Y.S. Pradana, H. Sudibyo, E.A. Suyonob, Indarto, and A. Budiman, "Oil algae extraction of selected microalgae species grown in monoculture and mixed

- cultures for biodiesel production”, to be published in *Energy Procedia*, 00 (2016), 000-000.
- [25] P. Hidalgo, G. Ciudad, and R. Navia, “Evaluation of different solvent mixtures in esterifiable lipids extraction from microalgae *Botryococcus braunii* for biodiesel production”, *Bioresour Technol*, vol. 201, pp. 360–364, 2016.
- [26] S.P. Jeevan Kumar, V.K. Garlapati, A. Dash, P. Scholz, and R. Banerjee, “Sustainable green solvents and techniques for lipid extraction from microalgae: A review”, *Algal Research*, vol. 21, pp. 138–147, 2017.
- [27] X. Wang, B. Zhao, X. Tang, and X. Yang, “Comparison of direct and indirect pyrolysis of microalgae *Isochrysis*”, *Bioresour Technol*, vol. 179, pp. 58–62, 2015.
- [28] J. Samanya, A. Hornung, M. Jones, and P. Vale, “Thermal stability of Sewage Sludge Pyrolysis oil”, *Int. J. Renew. Energy Res*, vol. 1(3), pp. 66-74, 2011.
- [29] H.V. Ly, S-S. Kim, J.H. Choi, H.C. Wooc, and J. Kim, “Fast pyrolysis of *Saccharina japonica* alga in a fixed-bed reactor for bio-oil production”, *Energ Convers Manage*, vol. 122, pp. 526–534, 2016.
- [30] P.J. De Wild, H. Reith, and H.J. Heeres, “Biomass pyrolysis for chemicals”, *Biofuels*, vol. 2 (2), pp. 185-208, 2011.
- [31] M. Hu, Z. Chen, D. Guo, C. Liu, B. Xiao, Z. Hu, and S. Liu, “Thermogravimetric study on pyrolysis kinetics of *Chlorella pyrenoidosa* and bloom-forming cyanobacteria”, *Bioresour Technol*, vol. 177, pp. 41–50, 2015.
- [32] X. Miao, Q. Wu, and C. Yang, “Fast pyrolysis of microalgae to produce renewable fuels”, *J Anal Appl Pyrol*, vol. 71, pp. 855–863, 2004.
- [33] S. Mohapatra, “Hydrogen Production Technologies with Specific Reference to Biomass”, *Int. J. Renew. Energy Res*, Vol.2, No.3, 2012.
- [34] P. Pan, C. Hu, W. Yang, Y. Li, L. Dong, L. Zhu, and Y. Fan, “The direct pyrolysis and catalytic pyrolysis of *Nannochloropsis* sp. residue for renewable bio-oils”, *Bioresour Technol*, vol. 101(12), pp. 4593–4599, 2010.
- [35] K. Wang, R.C. Brown, S. Homsy, L. Martinez, and S.S. Sidhu, “Fast pyrolysis of microalgae remnants in a fluidized bed reactor for bio-oil and biochar production”, *Bioresour Technol*, vol. 127, pp. 494–499, 2013.
- [36] S.W. Kim, B.S. Koo, and D.H. Lee, “A comparative study of bio-oils from pyrolysis of microalgae and oil seed waste in a fluidized bed”, *Bioresour Technol*, vol. 162, pp. 96-102, 2014.
- [37] P. Duan, X. Bai, Y. Xu, A. Zhang, F. Wang, L. Zhang, and J. Miao, “Catalytic upgrading of crude algal oil using platinum/gamma alumina in supercritical water”, *Fuel*, vol. 109, pp. 225–233, 2013.
- [38] S. Ceylan, Y. Topcu, and Z. Ceylan, “Thermal behaviour and kinetics of alga *Polysiphonia elongata* biomass during pyrolysis”, *Bioresour Technol*, vol. 171, pp. 193–198, 2014.
- [39] T. Dickerson and J. Soria, “Catalytic fast pyrolysis: A review”, *Energy*, 6, 514-538; doi:10.3390/en6010514, 2013.
- [40] Daniyanto, Sutijan, Deendarlianto, and A. Budiman, “Reaction kinetic of pyrolysis in mechanism of pyrolysis-gasification process of dry torrefied-sugarcane bagasse”, *ARNP Journal of Engineering and Applied Sciences*, 11, Issue 16, 9974-9980, 2016.