

Design and Implementation of a Hysteresis Band Current Controller Three-Phase AC Chopper System

Nurbanu Catalbas*, Mehmet Cem Catalbas**, Sedat Sunter***

*Department of Electrical and Electronic Engineering, Faculty of Engineering, Ankara University, Ankara/Turkey

**Electronic Technology, Vocational High School Department, OSTIM Technical University Ankara/Turkey

***Department of Electrical and Electronic Engineering, Faculty of Engineering, Firat University, Elazığ/Turkey

(nurbanumacit@gmail.com, mcmecatalbas@gmail.com, ssunter@firat.edu.tr)

‡ Mehmet Cem Catalbas; OSTIM Technical University, 06374, OSTIM Ankara/Turkey, Tel: +90 312 386 10 92
mcmecatalbas@gmail.com

Received: 02.08.2019 Accepted: 29.03.2020

Abstract- In this study, a three-phase alternative current (AC) chopper circuit was designed and simulated using a hysteresis band current controller (HBCC) method. The HBCC method is often preferred in switching control of AC choppers. The AC chopper circuit, which is both simulated and designed in this study, was composed of six IGBTs. The control of the switches in the circuit was provided by the pulse width modulation (PWM) method and this control in the design was realized by a digital signal processor (DSP) microcontroller. The aim of both the simulation and the design was to examine the output harmonics by ensuring the high quality and efficient operation of the AC chopper circuit. Controlled by the PWM method, this simulation was performed using the MATLAB program. The importance of HBCC in the process of reducing the harmonics in the current was shown in real-time.

Keywords: AC chopper, DSP, current controller, adaptive chopper, PWM, HBCC

1. Introduction

The transformation of a specific signal into the desired value is the primary matter of the area of power electronics. There are several ways to carry out such transformations by using inductors, capacitors and semiconductor devices such as diodes, thyristors, MOSFETs and IGBTs. The range of total conversion power can vary largely from mW to MW levels. The efficiency of transmitted or converted power is a key element for today's limited energy sources and the area of power electronics provides a way to increase efficiency with different types of circuit topology and methods. In this study, a novel method that provides an alternative current (AC) signal with low harmonics for AC chopper systems was used. Several methods for the design of AC chopper systems were found in the literature review. Deraz et al. suggested a novel method to minimize AC harmonics by using current limiting soft starter [1]. Lui et

al. proposed a novel topology and control system to increase the efficiency of power electronic circuits [2]. Their novel pulse width modulation (PWM) based method decreased the switching losses in semiconductor devices. In their study, Derradji and Moussi put forward a system which used a fixed hysteresis band current controller system to increase the performance of AC choppers [3]. The claim of this proposed work is eliminated the negative parts of the PWM based system, for instance, delayed triggering angle, discontinuity and the harmonic which occurs in the load current. Belhaoucheta and Rahmania suggested a novel approach to minimize the harmonics at the outputs of AC choppers [4]. They emphasized the suitability and simplicity of using a hysteresis band current controller for a high-speed driver system. They controlled the error on the current curve to obtain a fixed frequency.

In the present study, two special circuits for the real-time implementation of a three-phase AC chopper system was

designed. The first circuit is the measurement circuit to obtain the value of load current and source voltage simultaneously and the second one is the power unit which includes power electronic components such as insulated-gate bipolar transistors (IGBTs) and snubbers. In this study, hysteresis band current control (HBCC) was the control system applied together with PWM to get rid of the noises caused by some elements used at the output of AC choppers. The HBCC technique proposed for the three-phase AC chopper was simulated with MATLAB/Simulink.

Detailed results were obtained for different operating points that contained various resource states. Since most of the potential faults can be eliminated, the load voltage and currents should be constantly kept stable in all these functional conditions [5]. It was seen that the results obtained in the simulations with the experimental designed circuit are close to each other. The rest of the paper is structured as follows: in section 2, brief information is given about AC choppers, in section 3, the information about PWM is given, in section 4 the HBCC technique is explained briefly, in section 5 the design process of the three-phase AC chopper is given and in section 6 the detailed results of the HBCC based three-phase AC chopper are given.

2. Alternative Current Chopper

Alternative current (AC) choppers are power electronic circuits used to obtain an alternative signal of varying amplitude from a constant AC source. In these circuits, the effective value of the output voltage is changed by cutting both half periods of AC voltage at certain angles. Thus, the AC voltage is obtained at the desired value.

As well as having positive characteristics these circuits have a significant negative feature: they bring harmonics to the load side. Such a result is undesirable in power electronic circuits. As the harmonic is a signal in which unwanted components, such as noise, are present this causes deviations from the desired or target frequency value. Because power electronic circuits are already widely used in industrial systems, this harmonic formation is also a serious problem.

The negative effects of harmonics effects both technical and commercial aspects. Harmonics are technically accompanied by disadvantages such as the increased neutral current, faulty operation of microprocessors, overloading of the compensation systems, overheating of the transformers and excessive audible operation, distortion of the waveform of the source voltage and increased losses.

Harmonic filters are used to eliminate these drawbacks. These filters get rid of such problems by eliminating the noise in the systems. In AC chopper systems, it may also be effective to trigger the switches on the switch with different control systems as well as use filters to eliminate the harmonics.

AC choppers have the disadvantages of causing high-value harmonics on both the grid and the load side and being unable to provide precise control. Commonly used

power electric devices such as the motor driver system draw harmonics from the grid. However, it is possible to eliminate such problems by developing semiconductor technology and control methods such as PWM control.

3. Pulse Width Modulation and Power Electronic

The PWM is a technique used to dampen the effects of noises on the input signal. The PWM technique is applied according to the switching states of the semiconductor elements. This technique is used to provide power control and support high-frequency power electronics circuits as well as convert the signal information into a transmittable signal. It generally reduces power loss and is easy to control. PWM is the control of the widths of the pulse voltages produced to obtain the desired analogue electrical value or the signal obtained at the output.

PWM is used in many fields of electricity and electronics for various purposes such as motor drives, power circuits, coding and decoding techniques. PWM is a technique that contributes to the development of semiconductor devices [4].

The most common PWM acquisition method is the comparison of a sinusoidal wave with a triangular wave. As a result of this comparison, the square wave PWM signal is obtained. The positive signal obtained from this comparison is applied to the switches in the positive group in the range of $0-\pi$, and in the negative group in the range of $\pi-2\pi$. The frequency of the triangular signal, which is considered to be the carrier, is usually kept constant and the frequency of this signal determines the switching frequency.

The amplitude and frequency of the sinusoidal signal can be changed to control the output voltage and frequency. It was determined that the most common way to create a PWM signal in the literature was to compare the sine wave and sawtooth (Fig.1).

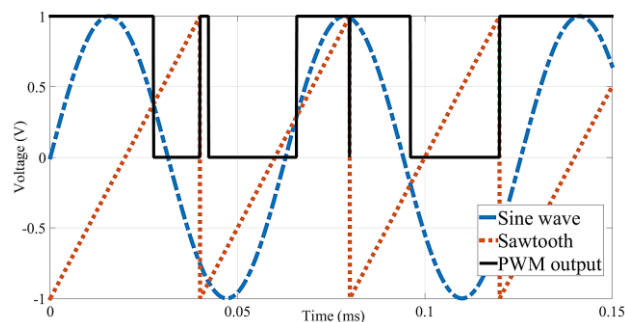

Fig. 1. Acquisition of driving signals by sampling PWM

In PWM control, the aim is to change the width of the pulses and the basic component of the output wave [6, 7]. PWM also contributes to the development of semiconductor devices [8]. Using PWMs with high-order switching frequencies in the development of semiconductors and microprocessors, it has become

possible to design large and cost-effective filter-free circuits. [9]. Besides, PWM can be used to improve product quality and provide more precise control. Since the PWM signal is a high-frequency signal, it is necessary to select a semiconductor switch that can respond to this frequency [10].

4. Hysteresis Band Current Controller (HBCC)

The control system that will be applied to get rid of the noise caused by some elements used in the output of alternating current choppers is the Hysteresis Band Current Controller (HBCC). The HBCC technique is a closed-loop controlled with instant feedback. The controllers created by the HBCC technique in most power electronics applications pay special attention to provide PWM signal control for the switch drivers [5]. This technique regulates interphase interaction when the natural load (continuous load) of the motor changes between the phases by creating a variable hysteresis band [11, 12]. As a result of this technique was shown a significant improvement in the quality of load current at the system simulation. This technique is practically important because it is created by factors that define the ease, cost and reliability of the industrial order. Moreover, with the current technological developments, the ease of this new technique has been proven by MATLAB / Simulink.

In this study, the design of the circuit was performed based on the simulation made with MATLAB, which is presented in Fig. 2 [11]. In the simulation, IGBT was used as a semiconductor switch and R-L load was connected as delta.

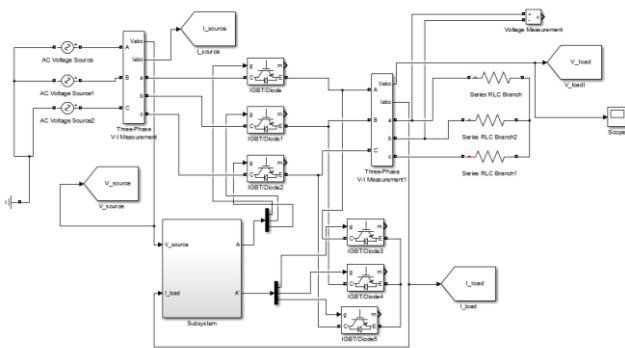

Fig. 1. Simulink model of the three-phase AC chopper

In the subsystem sub-block, the detailed state of the HBCC used was established. The reference current, the load angle, the minimum voltage algorithm, the triggering status of the switches, the generated hysteresis controller were performed in this sub-block.

Load synchronization was also performed when creating the minimum voltage algorithm. For load synchronization,

abc-dq0 (Park and Clark transform) conversion was applied between the load current, the reference current and the phase angle, and the sizes of the three phases were carried to two dimensions on the reference axis system. By this way, the two-dimensional signal was filtered in the circuit simulation and the result was created by using an arctangent to obtain the angle value. This angle value was then compared with another angle value. The pulse voltage was obtained by comparing the reference current value with the load current and combining them with the relay block. This pulse voltage was then applied to the IGBTs. The 3-phase AC Chopper system is shown in Fig. 3 [13].

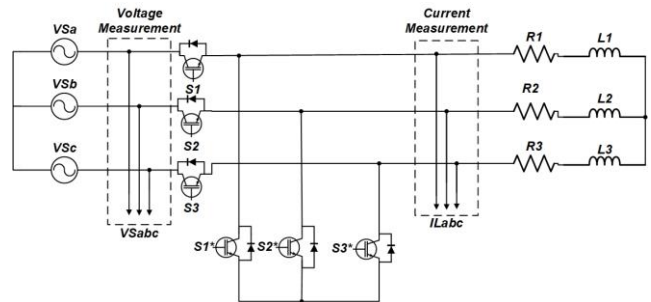

Fig.3. Power Circuit of 3 phase AC Chopper

The simulation result of the HBCC system has been worked in several works in the literature [11-13]. In this paper, the real-time implementation of HBCC based three-phase AC Chopper has been designed. There are eight states on the switching process of HBCC methodology. The states are shown in Table 1 [13].

Table 1. Switching State of Three Phase AC Chopper

States	S ₁	S ₂	S ₃	S ₁ *	S ₂ *	S ₃ *
1	0	0	0	1	1	1
2	0	0	1	1	1	0
3	0	1	0	1	0	1
4	0	1	1	1	0	0
5	1	0	0	0	1	1
6	1	0	1	0	1	0
7	1	1	0	0	0	1
8	1	1	1	0	0	0

5. Design of Three-Phase AC Chopper

In this section, the design of the three-phase AC chopper was described. The Eagle program was used as a printed circuit program in the design process.

The circuits in the design of the three-phase AC chopper consisted of power and control circuits. The power circuit was formed of a three-phase grid, a three-phase AC chopper and a load. Triangular R-L loads were used as loads. The control circuit of the design consisted of a dead time circuit, current-voltage measurements and a digital signal processor (DSP). A block diagram of these circuits is shown in Fig. 4.

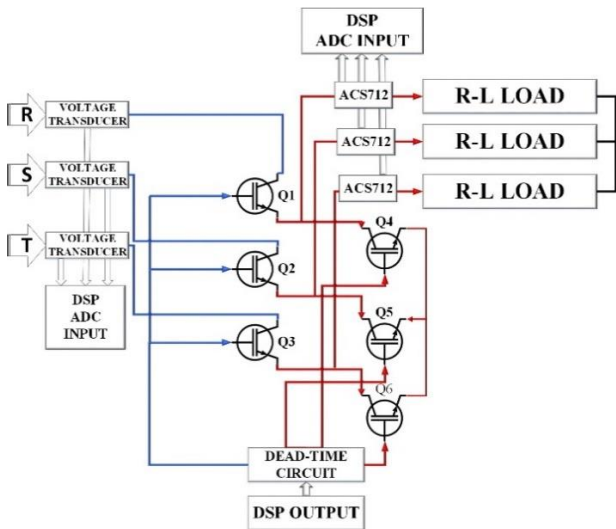

Fig. 4. Block diagram of the three-phase AC chopper

As can be seen from Fig. 4, the three-phase AC grid voltage was used as an AC source in the experimental stage. This grid voltage was connected to three single-phase transformers and converted to a lower voltage for safe operation. An IGBT (1200 V, 20 A) was used as a semiconductor element for both circuit simulation and circuit design.

The IGBT driver circuit used in this study is shown in Fig. 5. Each IGBT in the AC chopper circuit required a separate drive circuit. It was necessary to use a driver circuit that could provide a positive and negative voltage between the gate and the emitter of the IGBT. However, to make this more useful, M57962L was used as a driver integration with the same function. As six IGBTs were used in this study, six-driver circuit models, which are given in Fig. 5, were used.

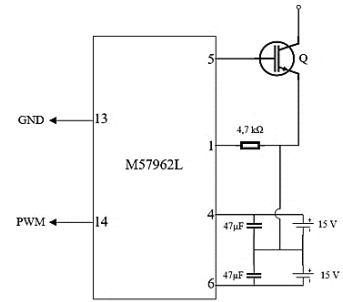

Fig. 5. Circuit diagram of IGBT driver used in circuit

Fig. 6 shows the printed circuit board of the IGBT driver circuit. The regulators were used to supply the DC-DC converters in this circuit. The converters required approximately 24 V. The capacities were used to filter the noise that may occur in the DC voltage in the circuit. Figure 5 shows the two regulators that were used. One was used for DC-DC converters and the other for dead time circuit.

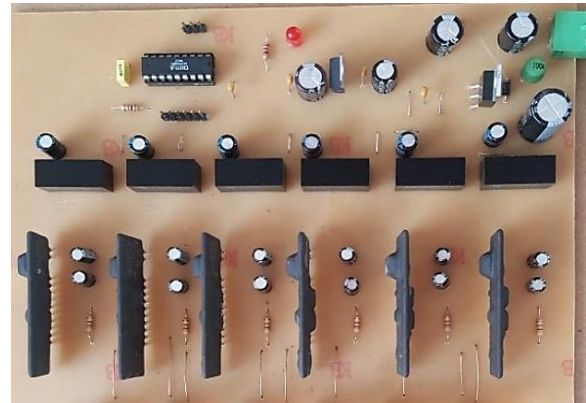

Fig. 6. IGBT drive print circuit used in the design

The dead-time circuit is a circuit that prevents the switches connected to the same phase to remain simultaneously transmitted and short-circuited. The dead-time circuit consists of two controllable delay circuits [14]. The schema and design of this circuit are given in Fig. 7.

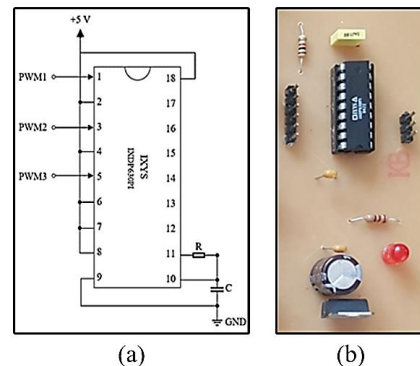

Fig. 7. Dead time circuit (a) design (b) circuit

The duration of dead time is extremely important. If the dead time is kept short, the switches and other components in the AC chopper circuit may be damaged. Keeping the time short may cause the switches in the same phase to remain at the same time [15]. When the switches were analyzed it was found that the dead time duration for the circuit used in this study was between 700 ns-1 μ s. The comparison of the dead time values and the resistance values are given in Table 2. As shown in the table, the desired value of dead time can be obtained by changing the value of resistance. For the process of dead time estimation, the value of capacitance was determined at a fixed value of 1 nF. According to this table, the optimal value of dead-time circuit can be obtained. The optimal time of dead-time can be changed according to several parameters. The parameters are types of switches,

Table 2. The change in dead time according to the resistance value

Resistance Value	Dead Time
1 k Ω	7 μ s
500 Ω	3 μ s
180 Ω	1,4 μ s
90,9 Ω	1,14 μ s
69 Ω	900 ns

The dead-time circuit given in Fig. 8 was measured using an oscilloscope.

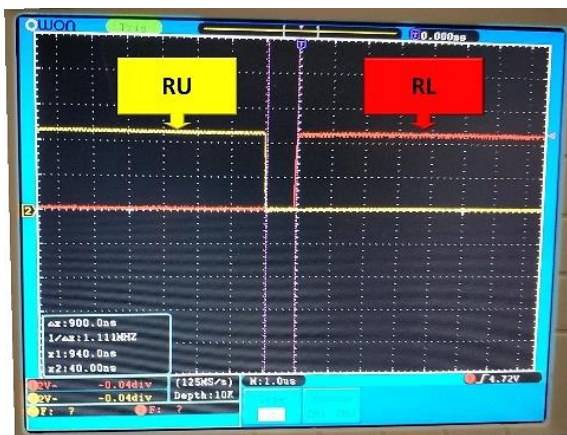

Fig.8. Dead time circuit signal

The signal specified as Channel 1 in Fig. 8 was the PWM signal applied to the input of the dead time circuit, while the signal specified as Channel 2 is the signal applied to the switch. As shown in Fig. 7, the value of dead time is approximately 900 ns. The value of capacitance was 1 nF and the resistance value was approximately 69 Ω .

This value was suitable for the switching times of the switches used in the AC chopper circuit. Figure 9 shows the laboratory environment in which the AC chopper circuit test was conducted.

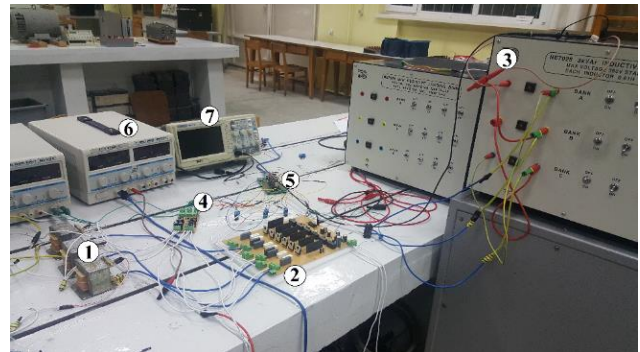

Fig. 9. Laboratory environment for AC chopper circuit testing (1) Transformer group 2) Power circuit 3) R-L load banks 4) Measuring circuit 5) DSP 6) DC power supply 7) Oscilloscope)

The signal to the IGBT drive circuit was provided by the DSP shown in Fig. 10, which can communicate with MATLAB [16]. The signal from the DSP was the PWM signal applied to the switches [17]. By means of this signal, the switches enabled them to operate in transmission or be interrupted with a certain algorithm.

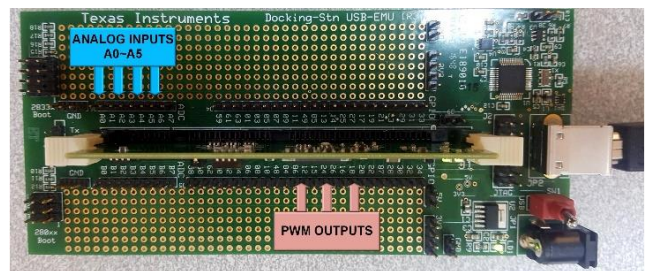

Fig.10. DSP (TMS320F28335)

The switching signals applied to the switches in the circuit are given in Fig. 11.

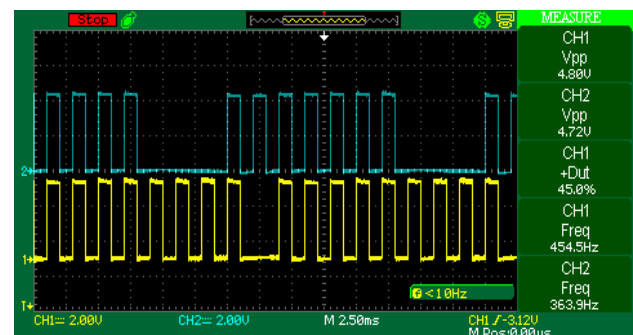

Fig. 11. Switching signals applied to the IGBTs

A total of six IGBTs were used as switches in the AC chopper circuit. Snubber circuits were used separately for each IGBT. The snubber circuits ensured the safe operation of the AC chopper circuit. Figure 12 shows the snubber circuit diagram [18].

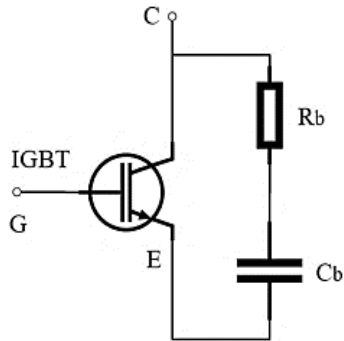

Fig. 12. Snubber circuit diagram

6. Results

The three single-phase transformers, which were connected to the grid voltage of the primary windings, had a voltage of 50 Hz and approximately 17 V from the secondary windings. The switching frequency was 1 kHz. Delta connected R-L loads (8, 1 Ω and 375 mH) were used as the loads. Load voltage, current and required harmonic analysis were measured.

Figure 13 shows the line voltage waveform obtained from the delta connected R-L load. The phase and line voltages were equal to each other.

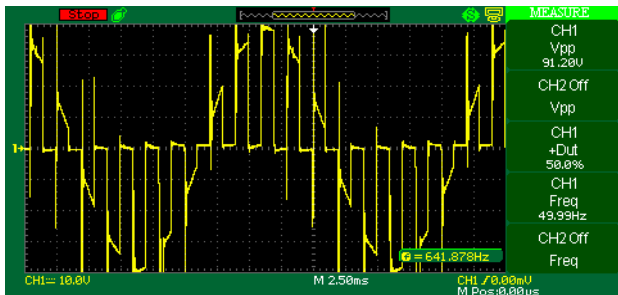
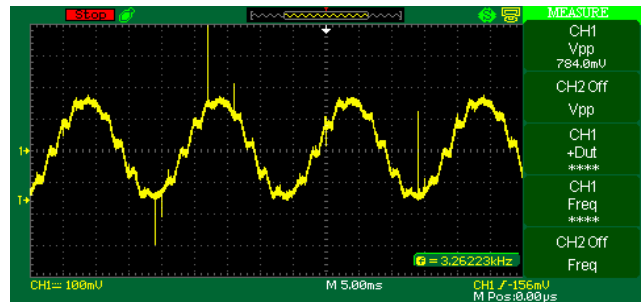
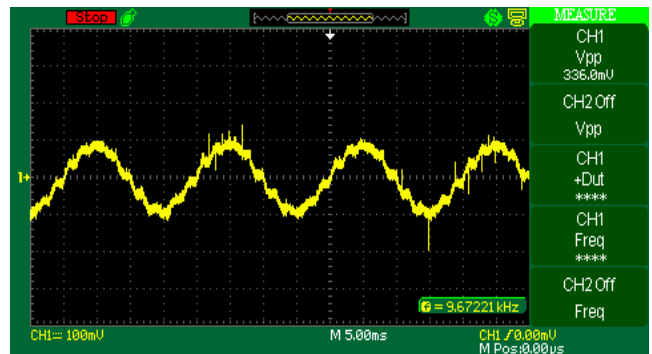

Fig. 13. Line voltage

Figure 14 shows the waveforms of the line and phase currents of the delta connected R-L load. To obtain the current waveform, 1 Ω and 1 W stone resistance were connected to the load and the voltage on the stone resistance was measured. The line current was measured to be approximately $\sqrt{3}$ times the load current.



(a)



(b)

Fig. 14. (a) Line current (b) Phase current

The voltage measurement result of the three-phase AC chopper system is shown in Fig. 15.

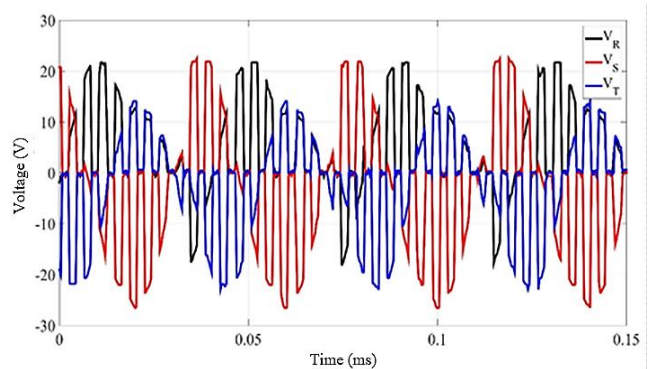

Fig. 15. The voltage result of the AC chopper

The graphs are given in Fig. 16 and 17 are the line voltage, the harmonic spectra of the line and phase currents of the delta connected R-L load [19]. Total harmonic distortion was determined as 42,2514% for the graph in Fig. 16, 20,853% for the graph in Fig. 16 and 17,603% for the graph in Fig. 18.

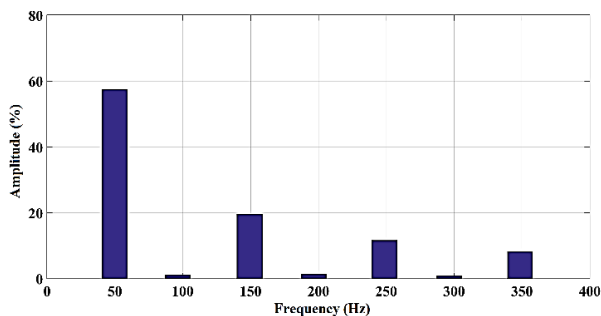

Fig. 16. Harmonic spectra of line voltage

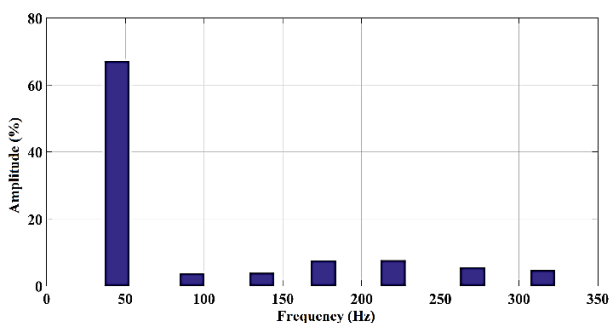

Fig. 17. Harmonic spectra of line current

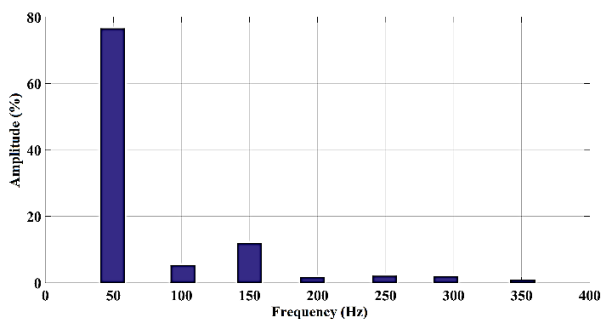

Fig. 18. Harmonic spectra of phase current

As shown in real-time experiment results, HBCC based three-phase AC Chopper system can be decreased percentage of THD about the proposed system. The three-phase Chopper system has several usage areas in literature. The speed control of motor, temperature, and industrial applications. In this paper, the result of different types of connection has been investigated. The variation according to different values of resistance for dead-time circuit output has been analyzed.

7. Conclusion

In this study, a real-time application of a three-phase AC chopper has been performed. The proposed PWM AC chopper circuit designed to convert a voltage of constant frequency and amplitude to a voltage with varying

amplitude was designed with different voltage values obtained from a three-phase source. The control process of the AC chopper system has been provided via the HBCC algorithm. The voltage and current measurement signals which are used on the switching states have been determined via circuits that are specially designed for this study. HBCC algorithm based switching state determination are realized on DSP. The delay time on the dead-time circuit has examined according to the different resistance values.

In light of these results, it was determined that the control structure applied in the experimental can be successfully decreased the percentage of total harmonic distortion. With the designed three-phase AC chopper circuit, it is thought that the harmonics generated in the grid can be reduced to a more acceptable level with more extensive studies regarding output voltage and output current.

Acknowledgements

This study was supported by Firat University, Institute of Scientific Research (FUBAP) within the scope of Research Project MF.17.28

References

- [1] S. A. Deraz, and H. Z. Azazi, "Current limiting soft starter for three phase induction motor drive system using PWM AC chopper", IET Power Electronics, Vol.10, No.11, pp. 1298-1306, 2017.
- [2] C. Liu, D. Guo, R. Shan, G. Cai, W. Ge, Z. Huang, and P.Wang,"Novel Bipolar-Type Direct AC-AC Converter Topology Based on Non-Differential AC Choppers", IEEE Transactions on Power Electronics, Vol.34, No.10, pp. 9585-9599, 2019.
- [3] K. Derradji Belloum, A. Moussi, "A Fixed Band Hysteresis Current Controller for Voltage Source AA Chopper", World academy of Science, Engineering and Technology International Journal of Electrical, Computer, Enegetic, Electronic and Communication Engineering, Vol:2, No:9, pp. 1813-1819, 2008.
- [4] N. Belhaoucheta, L. Rahmania, "Development of adaptive hysteresis-band current control of PWM three-phase AC chopper with constant switching frequency", Electr Power Compon. Syst, Vol. 37, No.6, pp. 583-598, 2009.

- [5] M. K. Metwaly, H. Z. Azazi, S. A. Deraz, M. E. Dessouki, and M. S. Zaky, "Power Factor Correction of Three-Phase PWM AC Chopper Fed Induction Motor Drive System Using HBCC Technique", IEEE Access, Vol. 7, pp. 43438-43452, 2019.
- [6] H. Yanmaz, "Design of a Pwm AC Chopper for Multi-Speed Permanent Split Capacitor Motors", Master Thesis, Düzce University, 2011.
- [7] B. Ahmad, W. Martinez, and J. Kyyrä, "Performance analysis of a transformerless solar inverter with modified PWM", 6th International Conference on Renewable Energy Research and Applications, San Diego, CA, 2017, pp. 1024-1029, 2017.
- [8] M. A. Sayed, K. Suzuki, T. Takeshita, and W. Kitagawa, "PWM Switching Technique for Three-Phase Bidirectional Grid-Tie DC-AC-AC Converter With High-Frequency Isolation", IEEE Transactions on Power Electronics, Vol. 33, No.1, pp. 845-858, 2017.
- [9] M. Hagemeyer, J. Solanki, N. Fröhleke, J. Böcker, A. Averberg, and P. Wallmeier, "Comparison of PWM AC chopper topologies", In Industrial Electronics Society, IECON 2014-40th Annual Conference of the IEEE, pp. 1325-1330, 2014.
- [10] N. Macit, "Design of Three Phase AC Chopper with Pulse Width Modulation", Master Thesis, Firat University, 2018.
- [11] N. Macit, S. Sünter, "PWM Control of AC Chopper Fed by Unbalanced 3-Phase VoltageSource", Firat University Turkish Journal of Science & Technology, Vol.12, No.2, pp.85-90, 2017.
- [12] S. Choudhury, P. K. Rout, "Design of fuzzy and HBCC based adaptive PI control strategy of an islanded microgrid system with solid-oxide fuel cell", International Journal of Renewable Energy Research, Vol.7, No.1, pp.34-48, 2017.
- [13] M. Kale, M. Karabacak, B. Saracoglu, "A novel hysteresis band current controller scheme for three-phase AC chopper", International Journal of Electrical Power & Energy Systems, Vol.44, No.1, pp.219-226, 2013.
- [14] L. F. Shi, F. B. Liu, H. S. He, X. Y. Mao, and X. Q. Lai, "Design of adaptive dead-time control circuit for resonant half-bridge driver", International Journal of Electronics, Vol.100, No.10, pp.1317-1331, 2013.
- [15] D. O. Neacsu, "Switching Power Converters: Medium and High Power", CRC Press, 2013.
- [16] M. J. Mnati, A. H. Ali, D. V. Bozalakov, S. Al-yousif, and A. V. D. Bossche, "Design and Implementation of a Gate Driver Circuit for Three-Phase Grid Tie Photovoltaic Inverter Application", 7th International Conference on Renewable Energy Research and Applications, Paris, 2018, pp. 701-706, 2018.
- [17] A. Elrajoubi, S. S. Ang, A. Abushaiba, "TMS320F28335 DSP programming using MATLAB Simulink embedded coder: Techniques and advancements", In 2017 IEEE 18th Workshop on Control and Modeling for Power Electronics, pp. 1-7, 2017.
- [18] K. Yatsugi, K. Nomura, Y. Hattori, "Analytical technique for designing an RC snubber circuit for ringing suppression in a phase-leg configuration", IEEE Transactions on Power Electronics, Vol. 33, No.6, pp. 4736-4745, 2017.
- [19] D. Shmilovitz, "On the definition of total harmonic distortion and its effect on measurement interpretation", IEEE Transactions on Power delivery, Vol.20, No.1, pp. 526-528, 2005.